

**ELECTROMAGNETIC FLOW METER**

**INSTALLATION MANUAL OF  
“FULL BORE” SENSORS**

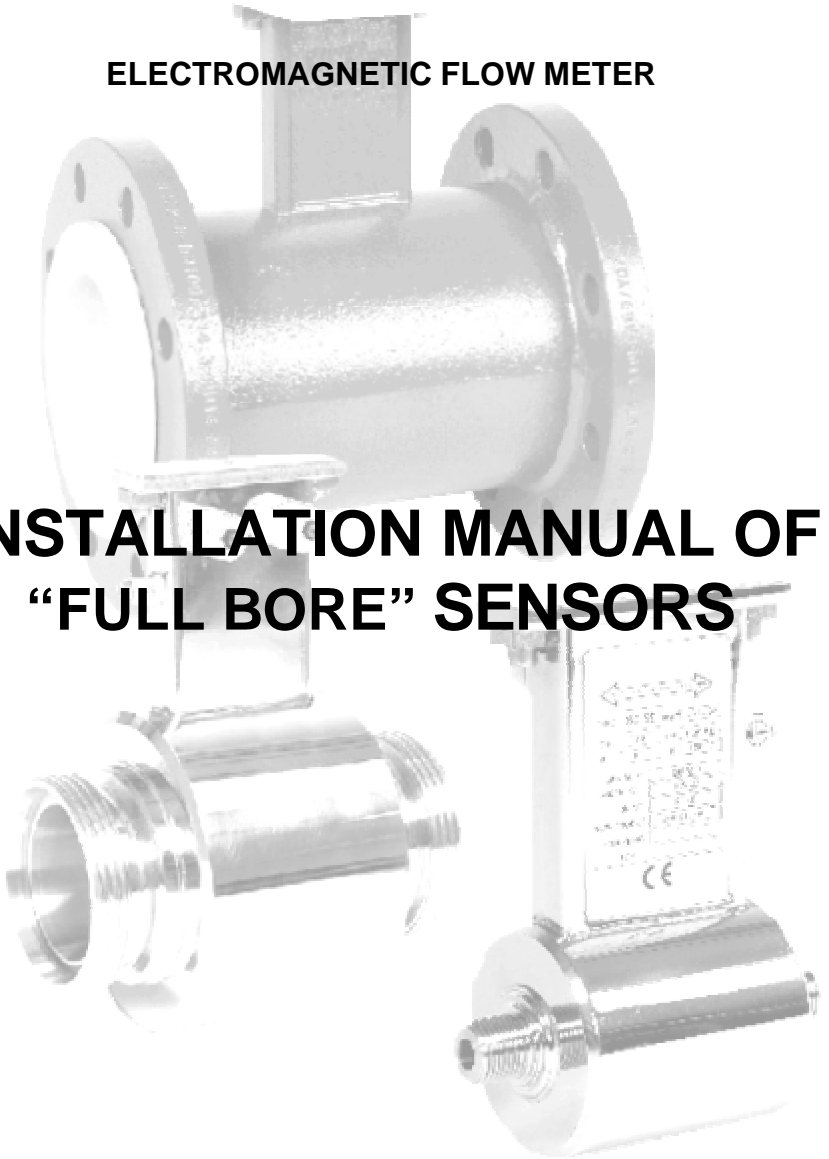

## □ INTRODUCTION

- This manual is integral part of the product. Read carefully the instructions contained in it since it contains important indications for the safety of use and of maintenance.
- The technical information and the relative products of this manual could undergo modifications without any previous notice.
- The flow meter must be used for the use it has been built for. The improper use, possible tampering of the instrument or parts of it and substitutions of any components not original, makes the warranty to decay automatically.
- The manufacturer is considered responsible only if the instrument is used in his original configuration.
- It's forbidden the reproduction of the present manual and of possible software supplied with the instrument.

## □ START UP AND MAINTENANCE OF THE INSTRUMENTS

- Before starting up the instrument, always make a sure connection to ground as suitable to page 5
- verify periodically: the integrity of the power supply cables, the tightening of the sealing elements (cable glands, covers, etc.), the mechanical fixing of the instrument on the pipe or on the wall stand.

## □ SAFETY



Before using the instrument, always make a sure connection to ground



Avoid any attempt to repair the instrument. If the instrument is not functioning properly, please call the nearest assistance service



Pay maximum attention during the operations



ATTENTION !!!



DANGER !!!

□ **GENERAL INFORMATION ON THE SENSORS INSTALLATION**

○ **Flow direction**

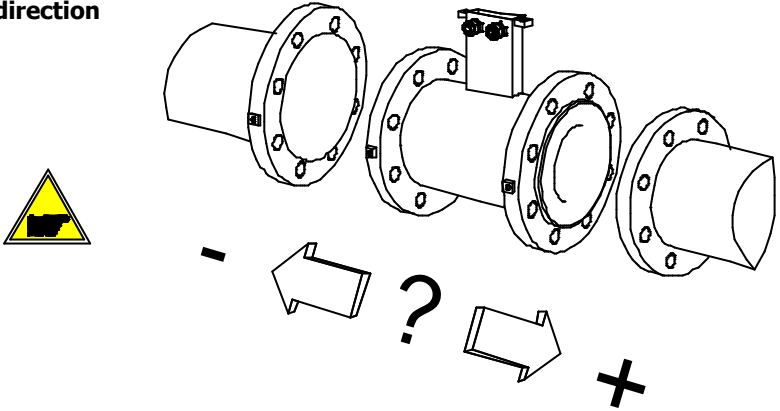

Before install the sensor locate the direction of the liquid in the piping  
 The sign of the flow rate **is positive**, when the flow direction it's from **- to +** as printed on the tag plate.

If after the installation, for plant request becomes necessary reverse the sign of the flow, it's enough reverse the sign of the coefficient KA

○ **Installation**

Method of upheaval recommended for ALL THE SENSOR EQUIPPED WITH EYEBOLT

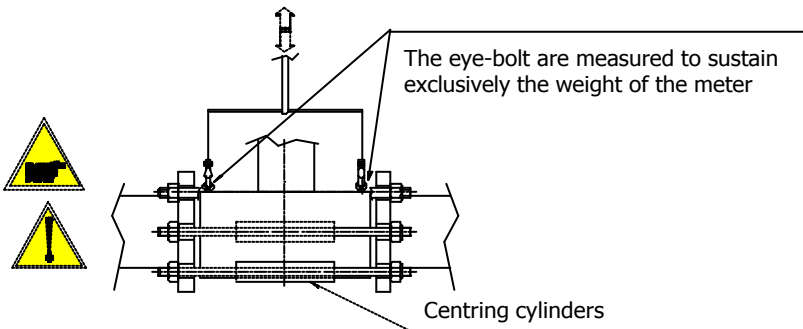

N.B.: For sensor MS 1000 we recommend the use of centring cylinders

To facilitate the installation operation, on the sensors with ND > 150 are assembled with eyebolts that they must be used as suitable in the drawing above.

○ **Shrewdnesses and precautions**

**NO**

**YES**

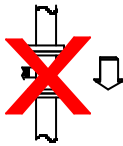

For vertical installations with descending flow direction contact the manufacturer

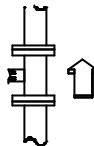

For vertical installations is preferable an ascending flow

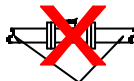

LONG PIPE

Avoid the installation of the sensor in a long pipe line, without any support of the same



ANTI VIBRATION JOINTS

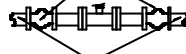

LONG PIPE

For installations on long pipe line, please use the anti vibration joints



Avoid the functioning with the pipe partially empty

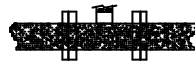

During the functioning the pipe must be completely full of liquid, or completely empty



Avoid the installation near curves or hydraulic accessories

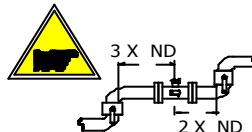

Install the sensor away from curves and hydraulic accessories



Avoid the approach of the flange and counter flange using the closing force of the nuts

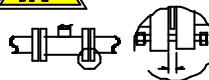

GASKET THICKNESS + 4mm

Before tightening the nuts approach as more possible the flange of the piping to the flange of the sensor

□ **OPERATING TEMPERATURES**

	EBONITE LINING				PP LINING				PTFE LINING			
	Liquid Temp.		Ambient Temp.		Liquid Temp.		Ambient Temp.		Liquid Temp.		Ambient Temp.	
	Min.	Max	Min.	Max	Min.	Max	Min.	Max	Min.	Max	Min.	Max
° C	0	80	-5	60	0	60	0	60	-20	150	-10	60
° F	30	176	23	140	32	140	32	140	-4	302	14	140

□ **GROUNDING INSTRUCTION**



For correct operation of the meter is NECESSARY that the sensor and the liquid are equipotential, so ALWAYS connect the sensor and converter to ground:

○ **Grounding with metallic pipe**

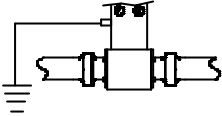

sensors with ground socket on the connection box

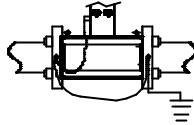

Wafer sensors

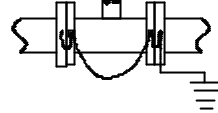

Flanged sensors

○ **Grounding with insulating pipe**

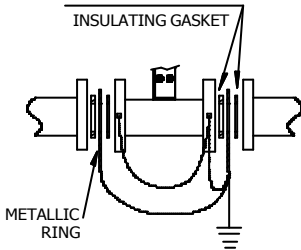

If the sensor has to be mounted on a pipe made of an insulating material is necessary:

- Install two metallic ring between the sensor flanges and the counter flanges of the pipe line or:

- Use a sensor with the additional grounding electrode

○ **Grounding with cathode protection pipe**

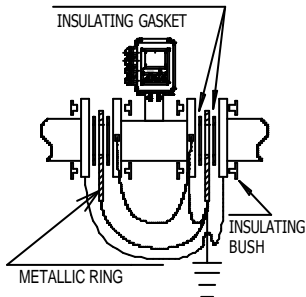

If the sensor must be install in the piping with a cathode protection, is necessary:

- using insulating bushes to isolate the bolts

- Grounding metallic rings should be provided to ground the liquid using insulating gasket between the rings

**TORQUES (lbf-ft) FOR BOLTS SENSOR MS 1000/2500**

Kpa psi	OPERATING PRESSURE (PSI)									
	1000		1600			2500		4000		6400
	140		260			350		600		1000
ND	PTFE	EBONITE	PTFE	EBONITE	PP	PTFE	EBONITE	PTFE	EBONITE	EBONITE
1"			18		14	18		18		29
1.25"			32		21	32		32		39
1.5"			39		27	39		39		53
2"			50		38	50		50		60
2.25"			66		55	33		33		43
3"			39		30	39		39		46
4"			43		41	61		61		64
5"			57		52	83		83		109
6"			80		78	100		100		160
8"	109	91	73	61		99	83	132	110	172
10"	91	76	103	86		151	125	197	165	238
12"	105	88	129	108		148	124	205	171	234
14"	127	106	151	126		239	199	311	260	355
16"	160	134	208	173		314	262	457	381	460
18"	143	119	207	173						
20"	165	137	282	235						
24"	238	198	419	350						

Tighten uniformly in diagonally opposite sequence

The torques listed are applicable to flanges UNI 2223, DIN 2501, BS 4504, ANSI B16.5

The use of flange gaskets (DIN 2690) is required.