



**FLOMOTION 900**

Ultrasonic Open Channel Flowmeter

USER'S MANUAL

JUNE 2009





**FLOMOTION 900**  
Ultrasonic Open Channel Flowmeter  
USER'S MANUAL

JUNE 2009



## **COPYRIGHT**

© Flomotion Systems, Inc. All rights reserved. No part of this publication may be reproduced, transmitted, transcribed, stored in a retrieval system, or translated into any language in any form without the written permission of Flomotion Systems, Inc.

## **WARRANTY AND LIABILITY**

Flomotion Systems guarantees for a period of 1 year from the date of delivery that it will either exchange or repair any part of this product returned to Flomotion Systems, Inc. If it is found to be defective in material or workmanship, subject to the defect not being due to unfair wear and tear, misuse, modification or alteration, accident, misapplication or negligence.

## **DISCLAIMER**

Flomotion Systems neither gives nor implies any process guarantee for this product, and shall have no liability in respect of any loss, injury or damage whatsoever arising out of the application or use of any product or circuit described herein.

Every effort has been made to ensure accuracy of this documentation, but Flomotion Systems cannot be held liable for any errors.

## **TECHNICAL ENQUIRIES**

Please contact Flomotion Systems for technical support.

## **FLOMOTION SYSTEMS, INC.**

165 Creekside Drive, Suite 112

Buffalo, New York 14228

U.S.A.

Tel: 716-691-3941 Fax: 716-691-1253

[www.FlomotionSystems.com](http://www.FlomotionSystems.com)

# Table of Contents

Chapter 1 Introduction .....	6
Features of FLOMOTION 900 .....	7
Product Specification .....	8
Chapter 2 Installation .....	9
Power Supply Requirements.....	9
Dimensions .....	9
Cable Entry.....	10
Sensor Installation .....	12
Leopold Lagco Flume.....	13
Chapter 3 How To Use FLOMOTION 900.....	15
Operating the controller .....	15
Button Functions.....	16
Chapter 4 Menu Guide .....	18
Application Menu Option .....	18
<i>Rect. Suppressed</i> .....	21
<i>Rect. Contracted</i> .....	21
<i>Cipolletti Weirs [Trapezoidal Weirs]</i> .....	22
<i>DIY Curve / Special</i> .....	24
<i>DIY Curve / Special</i> .....	24
<i>Q=K*H(PWR)</i> .....	25
Chapter 5 Digital Communication .....	41
Chapter 6 Maintenance .....	42
Chapter 7 Menu Option Record .....	43
< Appendix 1> Schematic Diagrams of Channels .....	44

# Chapter 1 Introduction

## About FLOMOTION 900

FLOMOTION 900 is an instrument that can be used both as ultrasonic open channel flow meter and level gauge. The ultrasonic open channel flow meter measures the water level and calculates and displays accurate flow rate and total flow rate in a manner to measure the flow rate according to a flow/level calculation method, based on the principle that water level is specifically related to flow rate in the standardized open channel.

The ultrasonic flow meter employing non-contact measurement method can be applicable to various fluids, including corrosive fluid, and has semi-permanent life.

Data Logger function is built in this product, enabling long-term storage of various data, such as level, flow rate, and total flow rate. These data can be saved for up to 6 months.

This product can be applicable to the following open channels.

1. Parshall Flumes
2. Suppressed Rectangular Weirs
3. Contracted Rectangular Weirs
4. V-Notch [Triangular] Weirs. [22.5°, 30°, 45°, 60°, 90°, 120°]
5. Cipolletti Weirs
6. Leopold Lagco Flumes
7. Palmer Bowlus Flumes

In addition, 10-point DIY CURVE and flow equation ( $Q=K \cdot H(PWR)$ ) are used to measure the flow rate in various open channels.

## Features of FLOMOTION 900

- Non-contact flow measurement - applicable to various fluids, semi-permanent life
- Applicable to various kinds of channels
- 10 point DIY CURVE function able to conduct flow measurement, regardless of the types of channels
- Digital measurement and display
- Current output in proportion to flow measurement (4mA ~ 20mA)
- Flow rate setting at 4mA ~20mA
- Flow-based pulse output (able to set unit flow rate) - applicable to mechanical flow meter
- 2 programmable SPDT relays
- 5 buttons for convenient and easy operation
- LCD to display operational conditions - convenient setting
- Built-in temperature sensor and temperature compensation function
- Ultrasonic output adjustment and algorithm selection assuring consistent flow measurement
- Automatic detection of bottom distance
- Storage of various data, including water level, flow rate, and total flow rate, for up to 6 months.
- Flow Switch input function able to measure the flow rate at Zero flow [Option]
- Operation with free voltage power, low power consumption

## Product Specification

### Physical

Controller	9.25"(width). X 7.3(height)
Sensor	Ø 2.61"(dia) X 6.0"(height)
Mounting	¾" NPT
Weight	6 lbs (sensor, controller)
Sensor Material	Polypropylene

### Environmental

IP Rating (electronics housing)	NEMA 4X/IP65(Controller)
Max. & Min. temperature (electronics)	-20 °C to +60 °C(Controller), -20 to +70°C(Sensor)
RTX cable length	32 ft. (Standard)

### Performance

Resolution	+/- .04 in.
Range(Flow rate)	0.00gal/min ~ 999999.0 gal/min
Range(Total flow)	999999999 gal
Range(level)	10 ft. (S100, 75kHz Transducer Assy)
Beam Angle	4° at -3dB (From the axis)
Response Time	500ms
Displayed Value	Flow rate, Total flow, Level , graphic LCD (128X68 dot)
Temperature Compensation	Fully compensated via integral temperature sensor over entire operational span

### Outputs

Analogue Output	4-20mA into Max 600Ω (user adjustable) Fault condition Alarm 3.8mA /hold/21mA,
Setpoint Relay	3 SPDT Relays
Relay capacity	5A, 250VAC
Communication Port	1 point RS-232C/RS485
Pulse output	1 point, open collector. Normally at +5VDC, switches to ground.

### Programming

On-board programming	via 5 tactile push button buttons
----------------------	-----------------------------------

### Supply

Power supply	90 ~ 260VAC, Less than 15VA(50Hz ~ 60Hz),
--------------	---

### Applicable Channel

Parshall Flumes-15 Sizes	Contracted Rectangular Weirs
Suppressed Rectangular Weirs	Cipolletti Weirs-10 Sizes
Leopold Lagco Flumes-10 Sizes	Palmer Bowlus Flumes-10 Sizes
V-Notch[Triangular] Weirs.[22.5°, 30°, 45°, 60°, 90°, 120°]	

### Special function

10 Point DIY CURVE
Flow equation(Q=K*H(PWR))

## Chapter 2 Installation

The FLOMOTION 900 is composed of one controller unit and one sensor

### Power Supply Requirements

The FLOMOTION 900 operates from an AC supply of 90 ~260V.

*All electronic products are susceptible to electrostatic shock, so follow proper grounding procedures during installation.*

When choosing a location to mount the sensor, bear in mind the following:

- For easy access to the LCD display and programming buttons mount it where it is easily accessible.
- The ultrasonic signal path should be free of falling material and obstructions such as pipes, beams etc.
- The sensor should be mounted at least 1.15 ft. above the maximum level of the material and be perpendicular to the surface.
- The mounting surface should be vibration-free.
- The ambient temperature of the sensor is between -20°C and 70°C.
- There should be no high voltage cables or electrical inverters close by.

### Dimensions

#### Sensor

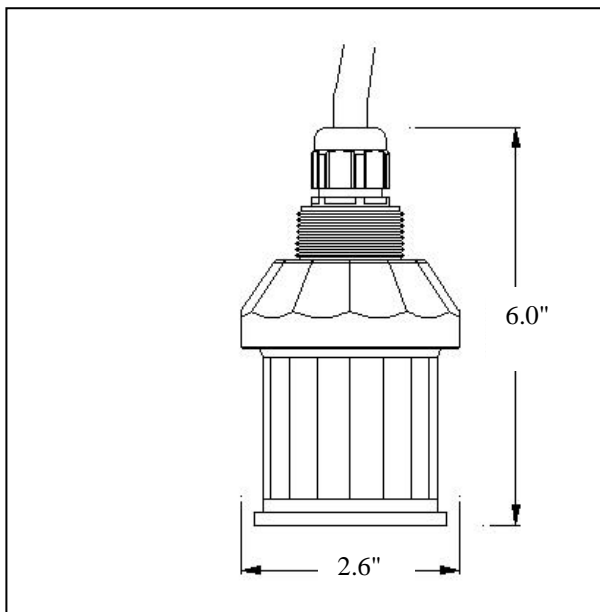

## Controller

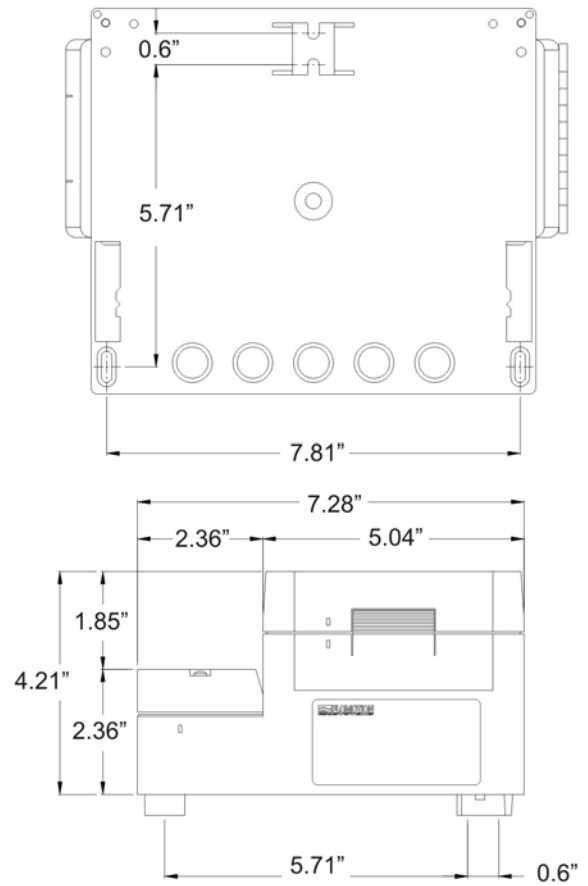
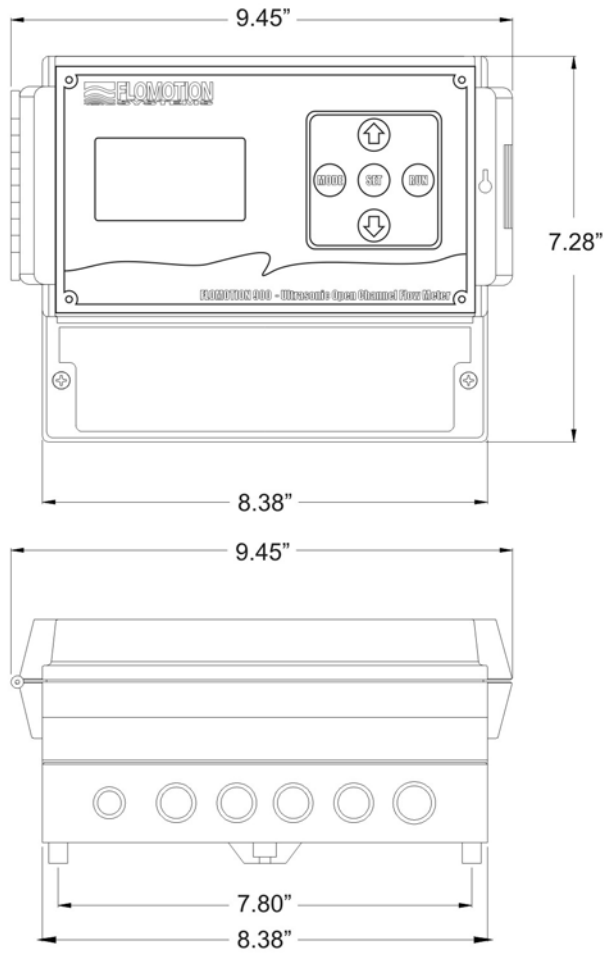

## Cable Entry

There are 20 terminals for controller and 3 terminals for power board as follows:

## Input & Output Terminal

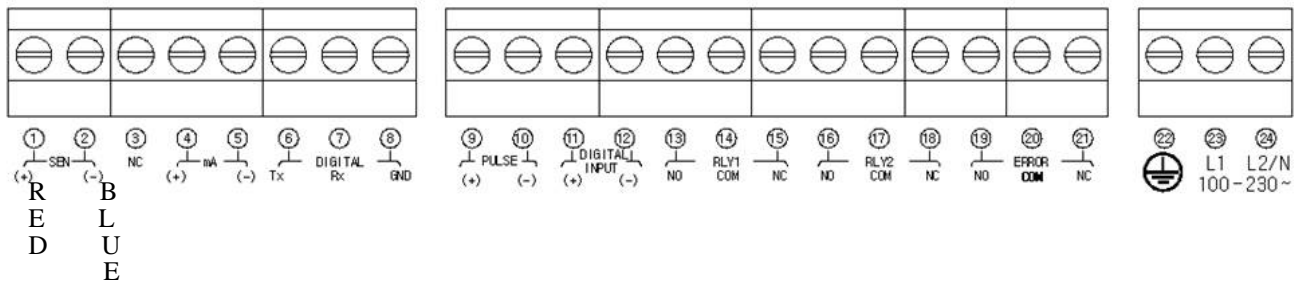

## Function

Terminal	Function	Note
SEN(+)	Connect to +cable of sensor of RTX	RED
SEN(-)	Connect to shield cable of sensor of RTX	BLUE
NC	Not Used	
mA(+)	Current output (+): Output of 4mA-20mA in proportion to flow rate.	MAX 600Ω
mA(-)	Current output (-)	
DIGITAL TX	When using RS232C interface, connection to RS232C's transmitter. When using RS485, connection to Y.	
DIGITAL RX	When using RS232C interface, connection to RS232C's receiver. When using RS485, connection to Z.	
DIGITAL GND	Digital communication GND	
PULSE(+)	Pulse output (+): at set intervals: Normally at +5VDC, switches to GND	
PULSE(-)	Pulse output (-)	
NC	Not Used	
NC	Not Used	
RLY1 NO	Relay_1 NO contact point. On operation of ALARM_1, disconnection from RLY1_COM	
RLY1 COM	Relay _1 COM contact point. Common contact point	
RLY1 NC	Relay _1 NC contact point. When ALARM_1 is not in operation, disconnection from RLY1_COM	
RLY2 NO	Relay _2 NO contact point. On operation of Relay_2, disconnection from RLY2_COM	
RLY2 COM	Relay _2 COM contact point, Common contact point	
RLY1(HH) NC	Relay _2 NC contact point. When Relay_2 is not in operation, disconnection from Relay2_COM	
ERROR NO	ERROR_NO contact point. On operation in ERROR situation, disconnection from ER_COM	
ERROR COM	ERROR_COM contact point. On operation in ERROR situation, disconnection from ER_NO & on its stop, disconnection from ER_NC	
ERROR NC	ERROR_NC contact point. When not operated even in ERROR situation, disconnection from ER_COM	
⊕	GND	
L2/N	AC power connection	
L1	AC power connection	

## Sensor Installation

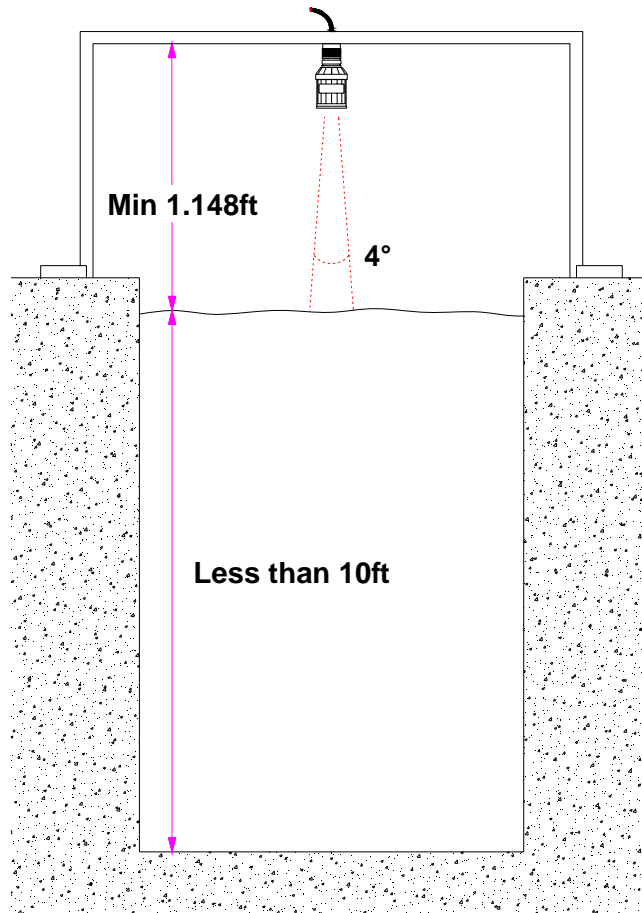

In order to prevent malfunctions and assure accurate measurement, installation should be conducted under consideration of the following points.

- 1) There should be no disturbing objects within the range of 4° beam angle where the ultrasonic pulse moves.
- 2) It should be installed at right angles to the water surface. (The sensor should be vertical to the floor.)
- 3) Input accurate bottom distance (see 04. BOTTOM DISTANCE).

The sensor should be installed at a position of above maximum water level of the channel to be measured (more than 1.148ft).

## Weir

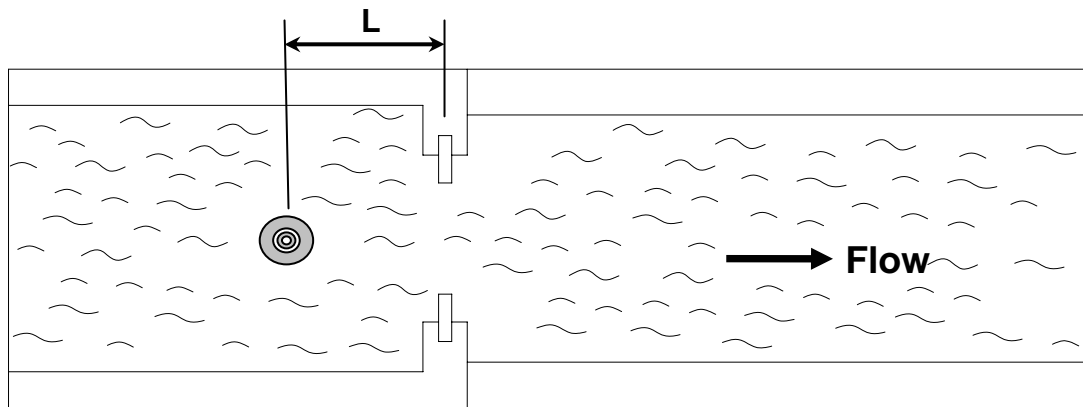

- In rectangular, v-notch (triangular), and Cipolletti weirs, the sensor should be installed in the center of the upstream channel 4-5 times max. liquid level from the weir plate.

## Parshall Flume

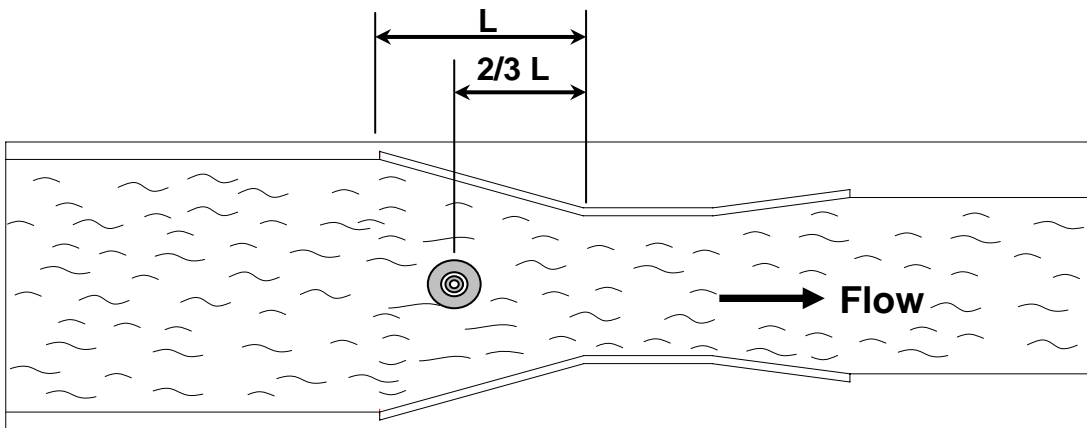

- In the Parshall Flume, the sensor should be installed at a  $2/3$  position of the whole converging section length.

## **Leopold Lagco Flume**

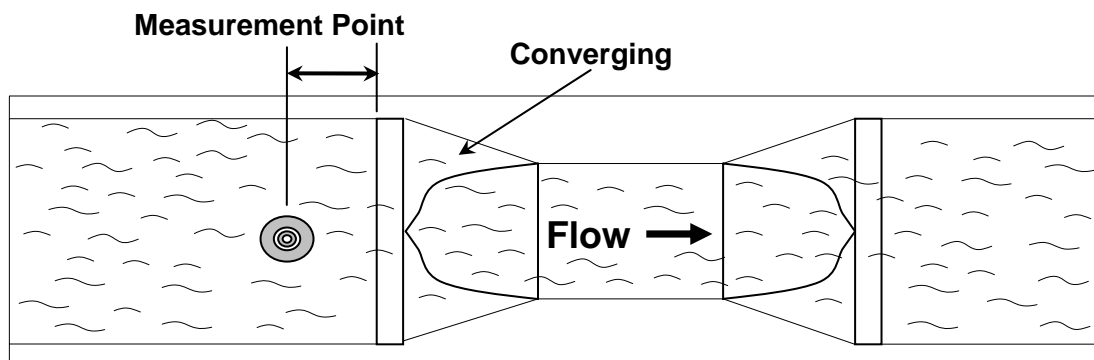

- In the Leopold-Lagco Flume, the sensor should be installed at a specific distance from the Converging Section (corresponding to the distance of measurement point according to Flumes size.) See below.

Flume Size		Measurement Point	
mm	inches	mm	inches
100 ~	4~12	25	1.0
380	15	32	1.3
455	18	38	1.5
530	21	44	1.8
610	24	51	2.1
760	30	64	2.5

- Blinking of "DT" at the bottom of the screen at Operation Mode means detection of water level. Therefore, such blinking should be confirmed in the course of installation.
- Installation should not be done at places exposed to direct sunlight or strong wind.
- After installation, operational conditions should be checked again (Power On/Off and display of measurement level).

**! Note: If not correctly installed, this product may not work properly in the winter when temperature difference between the sensor and the water surface is high.**

# Chapter 3 How To Use FLOMOTION 900

## Operating the controller

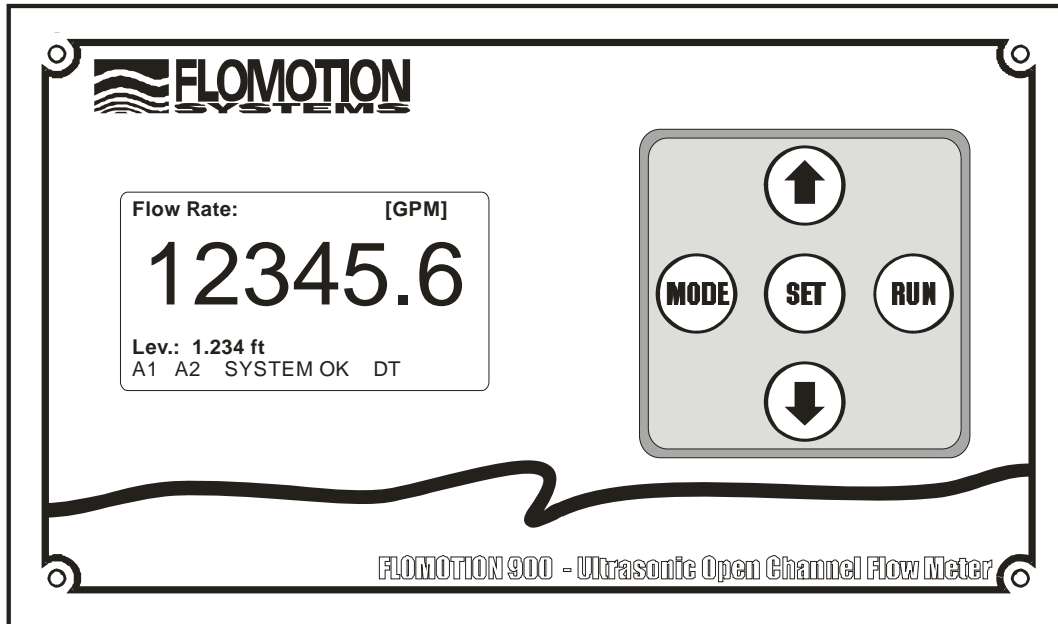

### Operation Mode I

- Push [SET] button at Operation Mode I and Operation Mode II will be displayed. Operation Mode II can be toggled to Operation Mode I by [SET] button.
- Operation Mode II shows the flow rate, total flow, total hour, water level, relay condition, and sensor status.
- You can choose Operation Mode I or II.

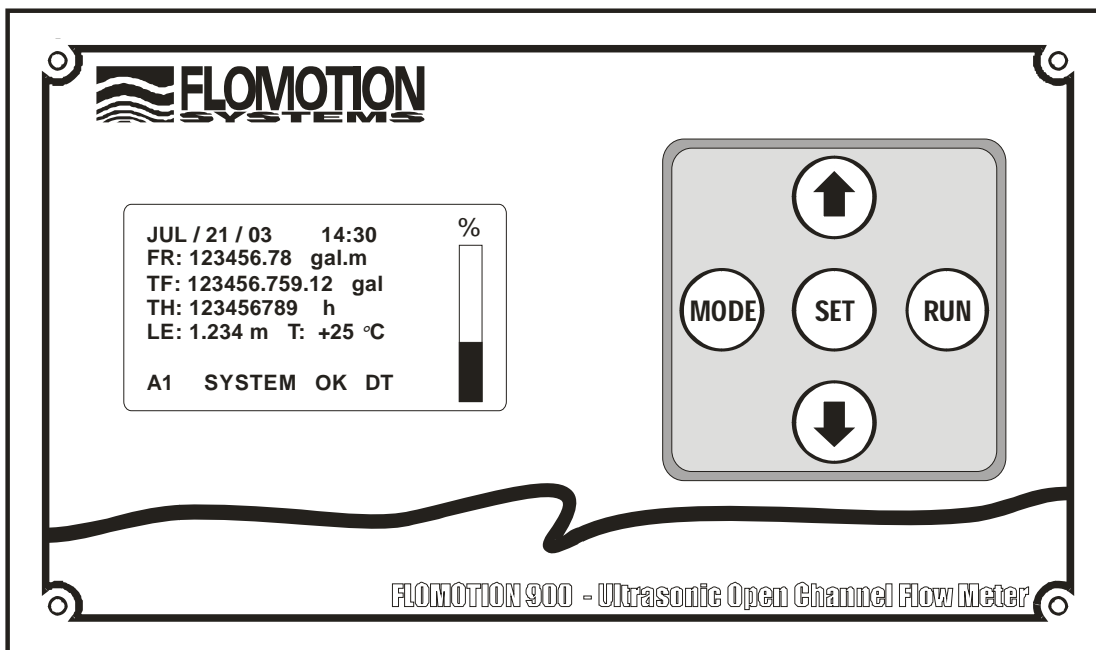

## Operation Mode II

- Description of abbreviations displayed

- 1) FR: Flow rate measured.
- 2) TF: Total flow from the set time.
- 3) TH: Total hours from the set time.
- 3) LE: Measured level from the bottom to the water surface in ft.
- 4) T: Ambient temperature.
- 5) Bar graph: Ratio of measured flow rate to max. flow rate.

- Description of characters displayed

FLOMOTION 900 shows its operational conditions on its LCD.

- 1) A1: RELAY1 is ON.
- 2) A2: RELAY2 is ON.
- 3) SYSTEM OK: System is normal.
- 4) FAIL: Failure to measure the flow rate.
- 5) DT: Flickered on normal measurement of water level.  
(meaning normal detection of reflected waves)
- 6) D Echo detection is okay
- 7) S: Searching Echo
- 8) LE: Lost echo. Failure to detect the reflected waves.

## Button Functions

### 1) MODE Button

- To convert Operation/Status Mode to Program Mode.
- Push MODE button at Operation/Status Mode and PASSWORD CHECK, the first menu of Program Mode, will be displayed.
- Push SET button and Program Mode will be immediately shown.
- At Program Mode, push Up or Down button to move to other menu option.
- Use MODE button to return to menu option after device/parameter is selected.

### 2) UP [↑] and DOWN [↓] Button

- Use this button to change the value of an option selected.
- One push of these buttons leads to increase by one. Continuous push of these buttons results in continuous increase one by one. A continuous push of this button results in changes of the number at tenth or hundredth figures.
- If a specific menu option is not selected, this button can be used to change menu options. One push of this button results in return to the previous menu or next menu option.

### 3) SET Button

- Use this button to save the value of an option.

### 4) RUN Button

- Use this button to return to Operation Mode from Program Mode.

# Chapter 4 Menu Guide

## Application Menu Option

### Password Check

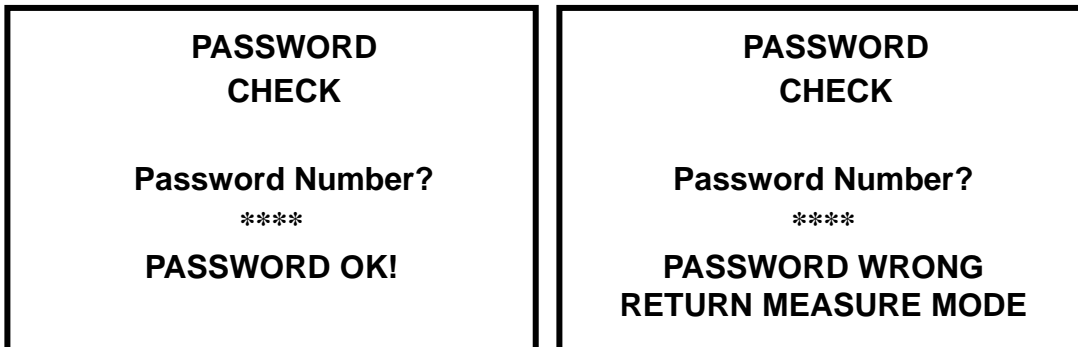

< When password is confirmed >

< When password is not confirmed >

- Push MODE button at Operation Mode and PASSWORD CHECK, the initial menu of Program Mode, will be displayed. This is a function to prevent changes of set values by unauthorized persons.
- If the password is wrong, "PASSWORD ERROR!" and "RETURN MEASURE MODE" will be displayed at the same time and it will return to Operation Mode.
- If the password is confirmed, "PASSWORD OK!" will be displayed and it will go to Program Mode.
- The password can be changed at PASSWORD CHANGE. The password numbers can be selected within the range of 0~1000.
- Use ↑ or ↓ to move to a specific menu. Place the cursor (\*) at a specific menu and push SET button. Then, you can change the value of the menu.
- If you don't want to change the value, push SET button and then, select another menu option.
- If you want to change the value, push ↑ or ↓ to change it. After change, push SET button to save the set value and then, select another menu.
- If you push RUN in the course of selecting an option, Program Mode is converted into Operation Mode.

## 1. SW Version

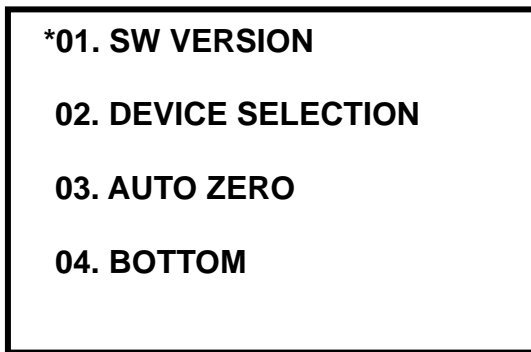

- This menu shows the S/W version of the unit.

## 2. Device Selection

Factory Set = 1

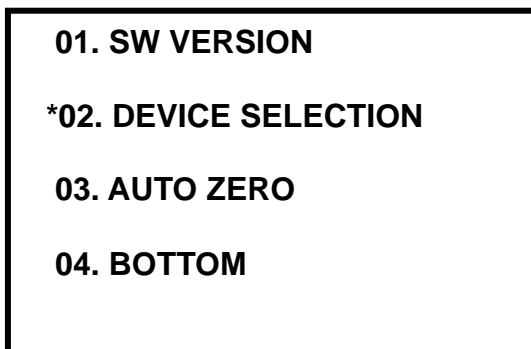

- This is an option for primary device selection and detailed parameter setting. Select the primary device first and then set the appropriate size.
- Place the cursor at this menu. Push SET button and the following screen I will be displayed. The initial value is 1. (Setting range: 1~8, Unit: 1)

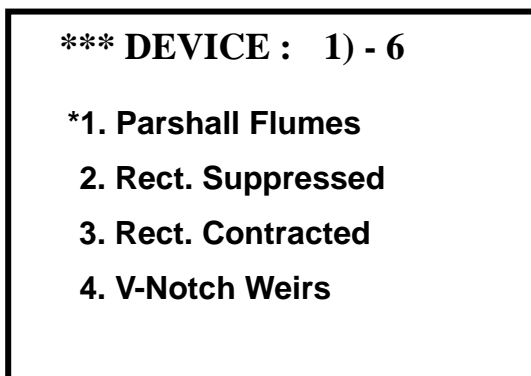

< 2. DEVICE SELECTION Screen I >

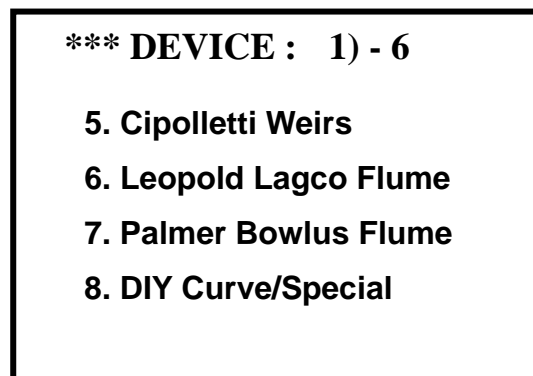

< 2. DEVICE SELECTION Screen II >

- At Program Mode, push ↑ or ↓ to place the cursor (\*) at a specific menu and push SET button to go

into the primary device desired.

- Push ↓ at No. 4 and Screen II showing No. 5 to 8 will be displayed. Also, push ↑ at No. 1 and the cursor will go to No. 8.
- Push MODE button to return to upper-level menu option.
- On selection of 2. DEVICE SELECTION menu, the primary device and max. flow rate value able to be measured will be automatically set.
- When the primary device is changed during measurement, the previously set values will be lost and values for menus (No. 7, 8, 9, 11, 14) will change to the corresponding primary device.

### Parshall flumes

Factory Set = 1

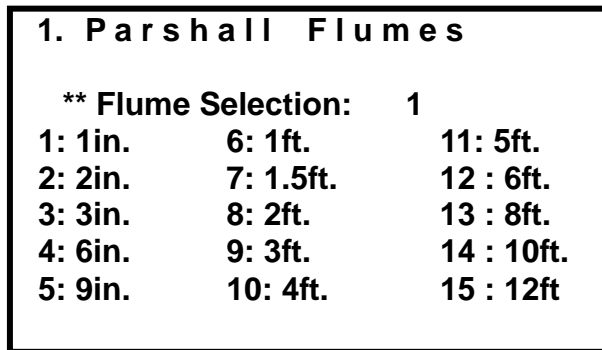

- Select Parshall Flumes and push SET button. Then, the menu for flume size selection will be displayed as shown in the above figure.
- Use ↑ or ↓ to select the appropriate size flume and push SET button to save the set value and return to main menu. (Setting range: 1~15, Unit: 1)
- Measurable maximum height is automatically set.

Parshall Flume	Max. Height [ft]	Parshall Flume	Max. Height [ft]
1"	0.6ft	9"	2.0ft
2"	0.6ft	1~8 ft	2.5ft
3"	1.5ft	10 ft	3.5ft
6"	1.5ft	12 ft	4.5ft

### **Rect. Suppressed**

Factory Set B = 1  
Factory Set D = 1  
Factory Set H = 1ft

### 2. Rect. Suppressed

\*\* Crest Length:            1

1: 1ft.	4: 2.5ft	7: 5ft.
2: 1.5ft.	5: 3ft.	8: 6ft.
3: 2ft.	6: 4ft.	9: 8ft.
		10: 10ft.

- Select Rect. Suppressed and push SET button. Then, the menu for selection of the rectangular weir will be displayed as shown in the above figure.
- Use ↑ or ↓ to select the appropriate size and push SET button to save the set values and return to main menu option. (Setting range: 1~10, Unit: 1)
- Measurable maximum height is automatically set.

Rect. Suppressed	Max. Height [ft]	Rect. Suppressed	Max. Height [ft]
1 ft	.5ft	4 ft	2.0ft
1.5ft	.75ft	5 ft	2.5ft
2 ft	1.0ft	6 ft	3.0ft
2.5 ft	1.25ft	8 ft	4.0ft
3 ft	1.5ft	10 ft	5.0ft

### **Rect. Contracted**

Factory Set B = 1  
Factory Set D = 1  
Factory Set b = 1  
Factory Set H = 1ft

### 3. Rect. Contracted

\*\* Crest Length:            1

1: 1ft.	2: 1.5ft.	3: 2ft.
4: 2.5ft.	7: 3ft.	6: 4ft.
7: 5ft.	8: 6ft.	9: 8ft.
10: 10ft.		

- Select Rect. Contracted and push SET button. Then, the menu for selection of the rectangular weir will be displayed as shown in the above figure.
- Use ↑ or ↓ to select the appropriate size and push SET button to save the set values and return to main menu. (Setting range: 1~10, Unit: 1)

- Measurable maximum height is automatically set.

Rect. Suppressed	Max. Height [ft]	Rect. Suppressed	Max. Height [ft]
1 ft	.5ft	4 ft	2.0ft
1.5ft	.75ft	5 ft	2.5ft
2 ft	1.0ft	6 ft	3.0ft
2.5 ft	1.25ft	8 ft	4.0ft
3 ft	1.5ft	10 ft	5.0ft

### ***V-Notch Weirs[Triangular]***

Factory Set= 1

**4. V-Notch Weirs**

**\*\* Weir Selection:            1**

**1: 22.5°      2: 30°      3: 45°**  
**4: 60°      5: 90°      6: 120°**

- Select V-Notch Weirs and push SET button. Then, the menu for selection of the v-notch weir will be displayed as shown in the above figure.
- Use ↑ or ↓ to select the appropriate size V-Notch Weir and push SET button to save the set values and return to menu option. (Setting range: 1~6, Unit: 1)
- Measurable maximum height is automatically set at 2ft..

### ***Cipolletti Weirs [Trapezoidal Weirs]***

Factory Set = 1

**5. Cipolletti Weirs**

**\*\* Weir Selection:            1**

**1: 1ft.      2: 1.5ft.      3: 2ft.**  
**4: 2.5ft.      7: 3ft.      6: 4ft.**  
**7: 5ft.      8: 6ft.      9: 8ft.**  
**10: 10ft.**

- Select Cipolletti Weirs and push SET button. Then, the menu for selection of the weir will be displayed as shown in the above figure.
- Use ↑ or ↓ to select the appropriate Cipolletti Weir and push SET button to save the set values and return to menu option. (Setting range: 1~10, Unit: 1)
- Measurable maximum height is automatically set.

Cipolletti Weirs	Max. Height [ft]	Cipolletti Weirs	Max. Height [ft]
1 ft	.5ft	4 ft	2.0ft
1.5ft	.75ft	5 ft	2.5ft
2 ft	1.0ft	6 ft	3.0ft
2.5 ft	1.25ft	8 ft	4.0ft
3 ft	1.50ft	10 ft	5.0ft

### Leopold Lagco Flumes

Factory Set = 1

**6. Leopold Lagco Flumes**

**\*\* Flume Selection: 1**

**1: 4in.    2: 6in.    3: 8in.**  
**4: 10in.    5: 12in.    6: 15in.**  
**7: 18in.    8: 21in.    9: 24in.**  
**10: 30in.**

- Select Leopold Lagco Flumes and push SET button. Then, the menu for selection of the flume will be displayed as shown in the above figure.
- Use ↑ or ↓ to select the appropriate Leopold Lagco Flume and push SET button to save the setting values and return to menu option. (Setting range: 1~10, Unit: 1)
- Measurable maximum height is automatically set.

Leopold Lagco Flumes	Max. Height [ft]	Leopold Lagco Flumes	Max. Height [ft]
4 inch	.25ft	15 inch	.9ft
6 inch	.3ft	18 inch	1.05ft
8 inch	.4ft	21 inch	1.25ft
10 inch	.6ft	24 inch	1.4ft
12 inch	.7ft	30 inch	1.7ft

### Palmer Bowlus Flumes

Factory Set = 1

**7. Palmer Bowlus Flumes**

**\*\* Flume Selection: 1**

**1: 4in.    2: 6in.    3: 8in.**  
**4: 10in.    5: 12in.    6: 15in.**  
**7: 18in.    8: 21in.    9: 24in.**  
**10: 27in.**

Leopold Lagco Flumes	Max. Height [ft]	Leopold Lagco Flumes	Max. Height [ft]
4 inch	.25ft	15 inch	.9ft
6 inch	.35ft	18 inch	1.05ft
8 inch	.5ft	21 inch	1.25ft
10 inch	.6ft	24 inch	1.4ft
12 inch	.7ft	27 inch	1.6ft

### DIY Curve / Special

Factory Set = 1

**8. DIY Curve/Special**

**\*\* Selection: 1**

**1 : DIY CURVE**  
**2 : Q=K\*H(PWR)**  
**3 : Rectangular Weir**

- Select DIY Curve / Special and push SET button. Then, an option for selection of 1. DIY Curve, 2. Q=K\*H\*PWR), or 3. Rectangular Weir will be displayed as shown in the above figure.
- This menu is used for measurement of flow rate, regardless of the type of device.
  1. DIY Curve: This option equally divides the known level-based flow rate into 10 parts and measures the flow rate according to change of level.
  2. Q=K\*H(PWR): This option inputs constant values, K and PWR, to an exponentially changing device and measures the flow rate.
  3. Rectangular Weir: This option selects Crest Length of all Rectangular Weirs in ft and measures the flow rate.
- Use ↑ or ↓ to select the relevant special option and push SET button to save the set values and return to menu option. (Setting range: 1~3, Unit: 1)

### DIY Curve / Special

**1. 10 POINT DIY CURVE**

**MAX. HEIGHT: 1.234ft**

**1) 0.1H: 123456.0 gal/m**  
**2) 0.2H: 123456.0 gal/m**  
**3) 0.3H: 123456.0 gal/m**  
**4) 0.4H: 123456.0 gal/m**

**1. 10 POINT DIY CURVE**

**5) 0.1H: 123456.0 gal/m**  
**6) 0.2H: 123456.0 gal/m**  
**7) 0.3H: 123456.0 gal/m**  
**8) 0.4H: 123456.0 gal/m**  
**9) 0.4H: 123456.0 gal/m**  
**10) 0.4H: 123456.0 gal/m**

- Select 1. DIY Curve and push SET button. Then, an option to input max. height of 1. 10 Point DIY Curve will be displayed as shown in the above figure.
- Use ↑ or ↓ to input measurable maximum height of the installed device and push SET button to save the value and go to an option for input of flow rate at 10% height. (Setting range: 0.1 ~ 99999.9 [gal/m])
- Use ↑ or ↓ to increase or decrease the value and input the relevant flow rate value and then, push SET button to save the flow rate value and go to an option for input of flow rate at 20% height. (Setting range: 0.1 ~ 99999.9 [gal/m])
- In this way, input the flow rate values corresponding to 30%, 40%, 50%, 60%, 70%, 80%, 90%, and 100%.
- After input of value for 100% with use of ↑ or ↓ button, push SET button to go to 2. DEVICE SELECTION. Push MODE button again to go to menu option.

**Q=K\*H(PWR)**

Factory Set = 1.234

**2. Q=K\*H(PWR)**

**K Constant : 1.234**

**KWR Constant : 1.234**

**H: Height [ft]**

- Select 2. Q=K\*H(PWR) and push SET button. Then, an option to input constants, K and PWR, will be displayed as shown in the above figure.
- Use ↑ or ↓ to input K constant, known or calculated, and push SET button to save the value and go to an option for input of PWR Constant. (Setting range: 0.001 ~ 9.999)
- In this way, input PWR Constant with use of ↑ or ↓ button and push SET button to save the value and return to 2. DEVICE SELECTION. (Setting range: 0.001 ~ 9.999)
- Push MODE button to return to main menu.

**Rectangular Weir**

Factory Set = 1

**3. Rectangular Weirs**

**\*Selection: 1**

**1. Suppressed Weir**

**2. Contracted Weir**

**\*Crest Length[ft]:**

**1.234**

- Select 3. Rectangular Weirs and push SET button. Then, two options to select the type of rectangular weir, \*Selection and \*Crest Length [m], will be displayed as shown in the above figure.
- If the weir is the suppressed weir, select 1. Suppressed Weir and push SET button. Then, move to the option for input of Crest Length [ft].
- In this way, select 2. Contracted Weir and set the relevant Crest Length. And push SET button to save the value and return to 2. DEVICE SELECTION. (Setting range: 1 ~ 2)
- Push MODE button to return to menu option.

### 3. Auto Zero

Factory Set = N/A

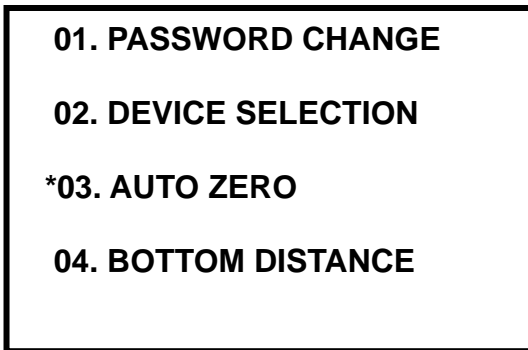

- This is an option for automatic detection of bottom distance from the sensor to the bottom or zero level/flow point. 04. BOTTOM DISTANCE is used for manual input of the distance from the sensor to the bottom or zero level/flow point
- Place the cursor at this option and push SET button. Then, the following screen will be displayed.

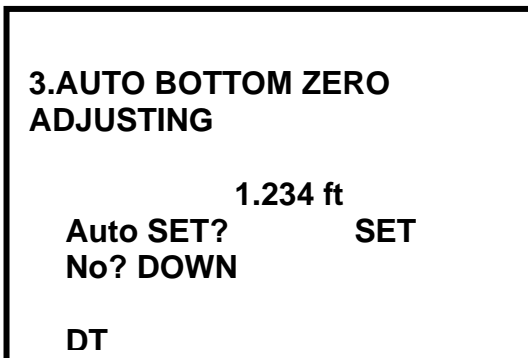

- DT will flicker and the distance will appear. When the distance is stabilized after damping time (measurement response rate), "Auto SET? SET, No? DOWN" will be displayed.
- If you want automatic setting of the measured value, push SET button. If not, push DOWN button and select other menu.

**NOTE** It is important to conduct the measurement when the inflow water level is the same as the bottom of the channel and there should be no water overflow in the channel. **If you select Auto, omit 04. BOTTOM DISTANCE.**

#### 4. Bottom Distance

Factory Set = 3.936ft

**01. PASSWORD CHANGE**

**02. DEVICE SELECTION**

**03. AUTO ZERO**

**\*04. BOTTOM DISTANCE**  
**1.234ft**

- This is an option to manually set the distance from the sensor to the bottom of the channel or zero level/flow point. For automatic setting, please refer to 3. AUTO ZERO.
- Since the flow meter is a device to measure the water level and convert it to a flow rate, it requires input of accurate distance measurement. Otherwise errors will occur.
- The unit for the distance is displayed in feet. Push SET button and the saved value will be displayed. In this condition, the value can be changed. Use ↑ or ↓ to input the desirable value. And push SET button again to save the value and return to main menu.
- Distance detection will not be done beyond the set value.

#### 5. Flow Index

Factory Set = Allowable Max. flow of selected device

**\*05. FLOW INDEX**

**06. 4mA POINT SET**

**07. 21mA POINT SET**

**08. RELAY1 ON POINT**

- Maximum flow rate based on the height of the channel can be searched gal/m.
- Place the cursor at this menu and push SET button. Then, the following screen will be displayed.

**5. MAX CHANGE VIEW**

1. 2 3 4m [1 2 3 4ft]

1 2 3 4 5 6 7.8 9 gal/h  
1 2 3 4 5 6 7.8 9 gal/min

- Use ↑ or ↓ to change maximum acceptable height and the flow rate. The initial value is the primary device maximum measurable height (Max Head) and flow rate.

**6. 4mA Point Set**

Factory Set = 0.00gpm

**05. FLOW INDEX**

**\*06. 4mA POINT**  
□□□□□□.□□ gal/m

**07. 20mA POINT**

**08. RELAY 1 ON POINT**

- This is an option for setting the flow rate value corresponding to 4 mA output. The set value determines flow rate at 4mA current output. In general, 0 is set. The initial value is 0.00 gpm. (Setting range: 0.00 ~ Max. Flow Rate, gpm)
- Push SET button to display the saved value and change it. Use ↑ or ↓ to input the desirable value. Push SET button again to save the value and return to main menu.

**7. 20mA Point Set**

Factory Set= Max. flow rate

**05. FLOW INDEX**

**06. 4mA POINT**

**\*07. 20mA POINT**  
□□□□□□.□□ gal/m

**08. RELAY 1 ON POINT**

- This is an option for setting the flow rate value corresponding to 20 mA output. The set value determines maximum flow rate at 20mA current output. The initial value is the maximum measurable flow rate (gal/m) of the device set in 02. (Setting range: 0.00 ~ Max. Flow Rate, Unit: gal/m)

### 8. Relay1 On Point

Factory Set= 10% of Max. flow value set at option 02 "Device Selection"

**05. MAX FLOW**  
**06. 4mA POINT**  
**07. 20mA POINT**  
**\*08. RELAY 1 ON POINT**  
 □□□□□□.□□ gal/m

- When the measured flow rate is below RELAY 1 On Point, the device's RELAY 1 is turned on. The initial value is the flow rate corresponding to 10% of the maximum measurable flow rate (gal/m) of the device set in 02. (Setting range: 0.00 ~ Max. Flow Rate, Unit: gal/m)

### 9. Relay1 Off Point

Factory Set= 20% of Max. flow value set at option 02 "Device Selection"

**\*09. RELAY 1 OFF POINT**  
 □□□□□□.□□ gal/m  
**10. RELAY 2 ON POINT**  
**11. RELAY 2 OFF POINT**  
**12. RELAY SIMULATION**

- When the measured flow rate is above RELAY 1 Off Point, the device's RELAY 1 is turned off.
- The initial value is the flow rate corresponding to 20% of the maximum measurable flow rate (gal/m) of the device set in 02. (Setting range: 0.00 ~ Max. Flow Rate, Unit: gal/m)

### 10. Relay2 On Point

Factory Set= 90% of Max. flow value set at option 02 "Device Selection"

**09. RELAY 1 OFF POINT**  
**\*10. RELAY 2 ON POINT**  
 □□□□□□.□□ gal/m  
**11. RELAY 2 OFF POINT**  
**12. RELAY SIMULATION**

- When the measured flow rate is above RELAY 2 On Point, the device's RELAY 2 is turned on.
- The initial value is the flow rate corresponding to 90% of the maximum measurable flow rate (gal/m) of the device set in 02. (Setting range: 0.00 ~ Max. Flow Rate, Unit: gal/m)

### 11. Relay2 Off Point

Factory Set= 80% of the Max. flow value set at option 02 "Device Selection"

**09. RELAY 1 OFF POINT**

**10. RELAY 2 ON POINT**

**\*11. RELAY 2 OFF POINT**  
 □□□□□□□.□□ gal/m

**12. RELAY SIMULATION**

- When the measured flow rate is below RELAY 2 Off Point, the device's RELAY 2 is turned off.
- The initial value is the flow rate corresponding to 80% of the maximum measurable flow rate (gal/m) of the device set in 02. (Setting range: 0.00 ~ Max. Flow Rate, gal/m)

#### <Examples of RELAY ON/OFF POINT Setting>

- RELAY1 & 2 can be used for generation of alarms (low or high flow) and control of water supply pump or drain pump.
- Example 1: Use of RELAY 1 for control of water supply pump (low flow alarm). If RELAY 1 ON POINT is set at 100.00 gal/m and OFF POINT is set at 200.00 gal/m, RELAY 1 is turned on when the flow rate is below 100.00 gal/m. If the water supply pump is turned on in this case, the water level is increased. When the level reaches OFF POINT (200.00 gal/m), RELAY 1 becomes off and the pump stops.
- Example 2: Use of RELAY 2 for control of water drain pump (high flow alarm). If RELAY 2 OFF POINT is set at 100.00 gal/m and ON POINT is set at 200.00 gal/m, RELAY 2 is turned on when the flow rate is above 200.00 gal/m. If the water drain pump is turned on in this case, the water level is decreased. When the level reaches OFF POINT (100.00 gal/m), RELAY 2 becomes off and the pump stops.

### 12. Relay Simulation

Factory Set =0.00 gal/m

**09. RELAY 1 OFF POINT**

**10. RELAY 2 ON POINT**

**11. RELAY 2 OFF POINT**

**\*12. RELAY SIMULATION**

- This is an option to check if RELAY is in normal operation after setting 08, 09, 10, and 11 items.

- Place the cursor at this menu and push SET button. Then, the following screen will be displayed.

RELAY SIMULATION	
R1 ON:	□□□□□□.□□ gal/m
R1 OFF:	□□□□□□.□□ gal/m
R2 ON:	□□□□□□.□□ gal/m
R2 OFF:	□□□□□□.□□ gal/m
FR:	□□□□□□.□□ gal/m
R1	R2

- This shows flow rate values set in 08, 09, 10, and 11. Further, virtual flow rates will flicker.
- Use ↑ or ↓ to adjust those virtual values. In this mode, operational conditions of R1 and R2 can be checked.
- When it is below R1 ON POINT, RELAY 1 will be turned on and A1 will be displayed. When it is above R1 OFF POINT, RELAY 1 will be turned off and A1 will disappear. When it is above R1 ON POINT, RELAY 2 will be turned on and A2 will be displayed. When it is below R1 OFF POINT, RELAY 2 will be turned off and A2 will disappear.

### 13. Low Cut Value

Factory Set = 0.00 gal/m

<b>*13. LOW CUT VALUE</b> □□□□□□.□□ gal/m
<b>14. HIGH CUT VALUE</b>
<b>15. TIME</b>
<b>16. TOTALIZER</b>

- This is an option to set minimum measurable flow rate. Flow rates below this value will be treated as "0". The initial value is 0.00 gal/m. (Setting range: 0.00 ~ Max. Flow Rate, gal/m)

### 14. High Cut Value

Factory Set = Max. flow rate

<b>13. LOW CUT VALUE</b>
<b>*14. HIGH CUT VALUE</b> □□□□□□.□□ gal/m
<b>15. TIME</b>
<b>16. TOTALIZER</b>

- This is an option to set maximum measurable flow rate. Flow rates above this value will be treated as the maximum flow rate or the enter value. The initial value is maximum flow rate of the device (gal/m). (Setting range: 0.00 ~ Max. Flow Rate, gal/m)

### 15. Time

Factory Set = N/A

**13. LOW CUT VALUE**  
**14. HIGH CUT VALUE**  
**\*15. TIME**  
**FEB/24/2002/ Fri 3:30**  
**16. TOTALIZER SET**

- Push SET button and the month/date/year/day and hour: minute will be displayed. If you don't want to change the value, push SET button again. If you want to change the value, push ↑ or ↓ to change the month. Push SET button again to change the date with use of ↑ or ↓. Continue to change the year, day, hour, and minute.

### 16. Totalizer Set

Factory Set = N/A

**13. LOW CUT VALUE**  
**14. HIGH CUT VALUE**  
**15. TIME**  
**\*16. TOTALIZER SET**

- This is an option to set or reset the initial values of total flow and total time.
- Place the cursor at this menu and push SET button. Then, the following screen will be displayed.

**TOTALIZER**

**1. Total Flow Set**  
 □□□□□□ . □□ gal

**2. Total Time Set**  
 □□□□□□ . □□ h

### Total Flow Set

- Use ↑ or ↓ to set the integral number of the initial value and push SET button to save value. The decimal number flickers automatically. Use ↑ or ↓ to set the value and push SET button to save the value (Setting range: 0.00 ~ 999999999.99, Unit: 0.01 gal).

### Total Time Set

- After completion of setting in 16-1), push SET button and values in Total Time Set will flicker. Use ↑ or ↓ to set total time and then, push SET button to save the value and go to other menu. (Setting range: 0 ~ 999999999, Unit: 1 h)

Delete all data previously saved.

### 17. Pulse Period

FactorySet = .10 sec

<p><b>*17. PULSE PERIOD</b> 0.10 sec</p> <p><b>18. PULSE VALUE</b></p> <p><b>19. DATA INTERVAL</b></p> <p><b>20. DATA TRANSFER</b></p>
--

- This is an option for setting the width for one pulse output according to the flow value set in No. 18. The initial value is .10 sec. (Setting range: .01 ~ 1.0, Unit: sec)

### 18. Pulse Value

FactorySet = 10 gal

<p><b>17. PULSE PERIOD</b></p> <p><b>*18. PULSE VALUE</b> □□□.□□ gal</p> <p><b>19. DATA INTERVAL</b></p> <p><b>20. DATA TRANSFER</b></p>
--

- This is an option for setting the flow value for output of one pulse.
- Pulse output is applicable to total flow meter in pulse count type and this menu determines the flow rate for one pulse. The initial value is 30.00 gal.

Minimum value of setting range is automatically limited against maximum measurable flow rate of the device.

## 19. Data Interval

FactorySet = 60 mins

**17. PULSE PERIOD**  
**18. PULSE VALUE**  
**\*19. DATA INTERVAL**  
□ . □ □ min  
**20. DATA TRANSFER**

- Period for storage of total flow data can be set.
- The period for storage of data can be calculated as follows:
- $\text{Min} \times 3 = (\text{day})$  In other words, if 10 minutes are set, data for about 30 days can be saved. When 30 days have passed, total flow data before 30 days are eliminated. Only the current total flow data for 30 days are saved.
- The initial value is 10 min. (Setting range: 1 ~ 60, Unit: 1 min)

## 20. Data Transfer

Factory Set = N/A

**17. DATA SAVE PERIOD**  
**18. PULSE VALUE**  
**19. PULSE PERIOD**  
**\*20. DATA TRANSFER**

- Place the cursor at this menu and push SET button. Then, data saved from the initial time to the present will be transferred according to RS-232 communication protocol (BPS: 9600, Parity Bit: None, Data Bit: 8, Stop Bit: 1).
- In the course of data transfer, "RS-232C Transfer!" and "STOP? DOWN" are repeated. If you want to stop data transfer, push DOWN for 2 seconds.
- On completion of data transfer, "RS-232C Transfer END!" will be displayed if there are no previous data. Push DOWN to go to other menu. If there is any previous data, "Want Before Data?" and "Yes? SET, No? DOWN" will be repeated.
- Push SET button for 2 seconds and the remaining data will be dumped. Push DOWN button to go to other menu. In the course of DUMP, "RS-232C Transfer!" and "STOP? DOWN" will be repeated. If you want to stop it in the course of DUMP, push DOWN button.

**17. DATA SAVE PERIOD**

**18. PULSE VALUE**

**19. PULSE PERIOD**

**\*20. DATA TRANSFER**

**Want Before Data ?**

```
2001/01/10 14/01 Memory restart! Save time:01min
2001/01/10 14/02 LE:0.194ft FR: 17.14gal/m TF: 4066.90gal
2001/01/10 14/03 LE:0.195ft FR: 17.28gal/m TF: 4067.19gal
2001/01/10 14/04 LE:0.194ft FR: 17.14gal/m TF: 4067.47gal
2001/01/10 14/05 LE:0.194ft FR: 17.14gal/m TF: 4067.75gal
2001/01/10 14/06 LE:0.194ft FR: 17.14gal/m TF: 4068.04gal
2001/01/10 14/07 LE:0.194ft FR: 17.14gal/m TF: 4068.33gal
2001/01/10 14/08 LE:0.194ft FR: 17.14gal/m TF: 4068.62gal
2001/01/10 14/09 LE:0.194ft FR: 17.14gal/m TF: 4068.90gal
2001/01/10 14/10 LE:0.194ft FR: 17.14gal/m TF: 4069.19gal
2001/01/10 14/11 Power on time! Save time:01min
2001/01/10 14/12 LE:0.194ft FR: 17.14gal/m TF: 4069.39gal
RS-232C Dump END!
Want Before Data? YES?SET,No?DOWN
2001/01/10 13/44 Power on time! Save time:01min
2001/01/10 13/45 LE:0.196ft FR: 17.41gal/m TF: 4063.44gal
2001/01/10 13/46 LE:0.195ft FR: 17.28gal/m TF: 4063.73gal
2001/01/10 13/47 LE:0.197ft FR: 17.55gal/m TF: 4064.01gal
2001/01/10 13/47 Power off time! Save time:01min
2001/01/10 13/50 Power on time! Save time:01min
2001/01/10 13/51 LE:0.197ft FR: 17.55gal/m TF: 4064.26gal
2001/01/10 13/52 LE:0.197ft FR: 17.55gal/m TF: 4064.55gal
2001/01/10 13/53 LE:0.194ft FR: 17.14gal/m TF: 4064.84gal
2001/01/10 13/54 Mode setup time! Save time:01min
2001/01/10 13/55 LE:0.194ft FR: 17.14gal/m TF: 4065.10gal
2001/01/10 13/56 LE:0.194ft FR: 17.14gal/m TF: 4065.39gal
2001/01/10 13/56 Mode setup time! Save time:01min
2001/01/10 13/57 LE:0.194ft FR: 17.14gal/m TF: 4065.47gal
2001/01/10 13/58 LE:0.194ft FR: 17.14gal/m TF: 4065.76gal
2001/01/10 13/59 LE:0.194ft FR: 17.14gal/m TF: 4066.04gal
2001/01/10 14/00 LE:0.194ft FR: 17.14gal/m TF: 4066.33gal
2001/01/10 14/01 LE:0.194ft FR: 17.14gal/m TF: 4066.61gal
RS-232C Dump END!
```

**<Example of Data Transfer displayed on PC>**

## 21. Blanking

Factory Set = 1.15 ft

<p><b>*21. BLANKING</b> □ . □ □ □      ft</p> <p><b>22. TRANSMIT POWER</b></p> <p><b>23. OUTPUT DAMPING</b></p> <p><b>24. FAIL SAFE CURRENT</b></p>
---

- In general, the ultrasonic sensor cannot detect any object within a specific distance from the sensor. The distance is about 0.82 ~ 1.3 ft for this product.
- If a user increases this value, false detection arising from an obstacle close to the sensor can be prevented.
- The initial value is 1.3 ft. (Setting range: 0.82 ~ 9.999, Unit: ft)

## 22. Transmit Power

Factory Set = 3

<p><b>21. BLANKING</b></p> <p><b>*22. TRANSMIT POWER</b> □</p> <p><b>23. OUTPUT DAMPING</b></p> <p><b>24. FAIL SAFE CURRENT</b></p>
---

- This is an option for setting the ultrasonic sensor's output. This menu adjusts the output and maintains optimal conditions under operating environments.
- Set low TRANSMIT POWER if there are many obstacles around it. Increase TRANSMIT POWER value for remote measurement or minimal foam/bubbles arise on the water surface.
- The initial value is set at 3, which is optimal setting under normal operating environments. (Setting range: 1 ~ 5)

### 23. Output Damping

Factory Set = 2

- 21. BLANKING
- 22. TRANSMIT POWER
- \*23. OUTPUT DAMPING
- 24. FAIL SAFE CURRENT

- This option determines the maximum rate at which the unit will respond to an increase/decrease in level.

- Setting Range :
  - 1 = 0.33ft/min (Slowest Response)
  - 2 = 1.64ft/min
  - 3 = 3.28ft/min
  - 4 = 32.8ft/min (Fastest Response)

### 24. Fail Safe Current

Factory Set = 3.8mA

- 21. BLANKING
- 22. TRANSMIT POWER
- 23. OUTPUT DAMPING
- \*24. FAIL SAFE CURRENT  
3.8mA

- This is an option for setting FAIL SAFE CURRENT. If the reflected wave is not sufficiently received, a specific current different from normal output current is generated to indicate the error. 3.8 mA, HOLD, or 21mA is used for this purpose.
- If measurement is not normally conducted, FAIL SAFE CURRENT is generated after FAIL SAFE TIME.
- If HOLD is set, the flow under HOLD is totalized. In the case of other settings, totalization is not conducted. The initial value is 3.8 mA. (Setting range: 3.8 mA, HOLD, 21 mA).

## 25. Fail Safe Time

Factory Set = 120 sec

<p><b>*25. FAIL SAFE TIME</b> □ □ □      <b>sec</b></p> <p><b>26. DETECT THRESHOLD</b></p> <p><b>27. 12mA OUTPUT</b></p> <p><b>28. FLOW SWITCH</b></p>
--

- This is an option for setting FAIL SAFE TIME. If the reflected wave is not sufficiently received, FAIL SAFE CURRENT output and ERROR relay operation are held for some time.
- The initial value is 120 sec. (Setting range: 20 ~ 999, Unit: 1 sec)

## 26. Detect Threshold

Factory Set = 8

<p><b>25. FAIL SAFE TIME</b></p> <p><b>*26. DETECT THRESHOLD</b> □</p> <p><b>27. 12mA OUTPUT</b></p> <p><b>28. FLOW SWITCH</b></p>
--

- This is an option for setting threshold for detection of the reflected wave. This menu adjusts the threshold for detection of the reflected wave and maintains optimal conditions under operating environments.
- To reduce the probability of false detection or at an environment generating lots of noise, increase the threshold value. For detection of weak signals, decrease the value. Set the threshold value according to the environmental conditions. The initial value is 8. (Setting range: 1 ~ 15, Unit: 1)

## 27. mA Output Test

<p><b>25. FAIL SAFE TIME</b></p> <p><b>26. DETECT THRESHOLD</b></p> <p><b>*27. mA OUTPUT TEST HOLD</b></p> <p><b>28. FLOW SWITCH</b></p>
--

- This is an option for 12 mA output, regardless of measurement result. Such output is used to check operation conditions of current output circuits and interface with other equipment. On returning to Operation Mode, this function is automatically cancelled.

## 28. Flow Rate Factor

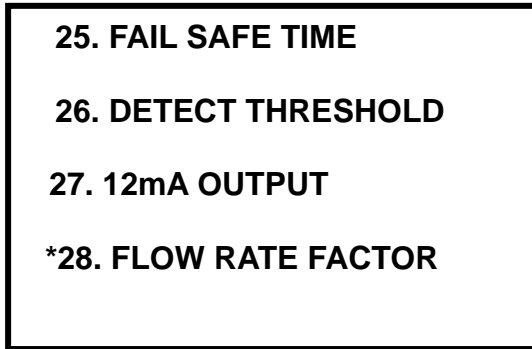

- This is an option to change the flow rate by entering a flow rate scale factor.
- Place the cursor at this menu and push SET button. Then, the following screen will be displayed.

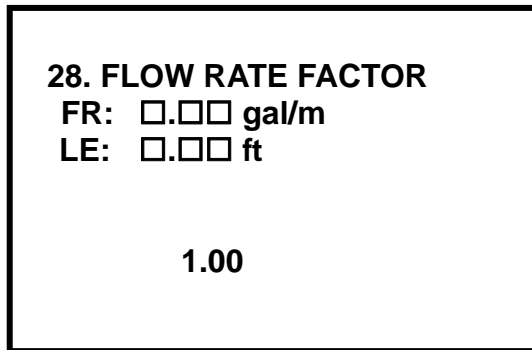

- Push SET button to display the saved value and change it. Use ↑ or ↓ to select the one you want. Push SET button again to save the value and return to main menu.

## 29. SYSTEM ID

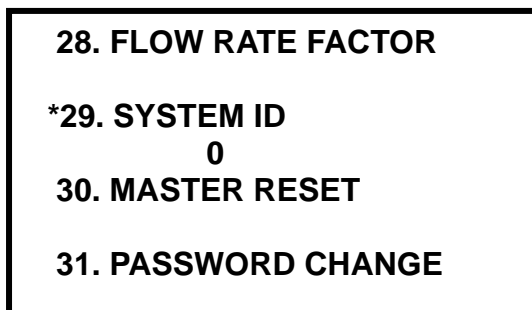

- This menu is for factory use only.

### 30. Master Reset

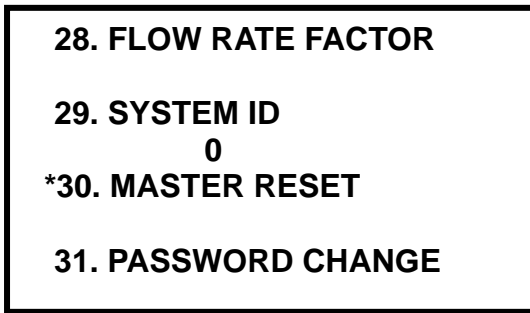

- This is an option for factory reset.
- Push SET button and you can reset the parameter as the factory reset by up and down key.

### 31. Password Change

Factory Set= 0

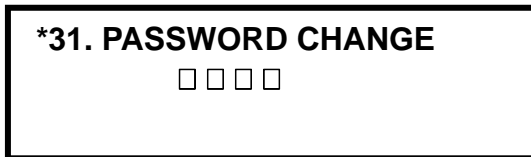

- This is an option for change of password. Push ↑ or ↓ to change the password.
- Push SET button and the changed password will be saved.
- The initial value is 0. (Setting range: 0~1000, Unit: 1)

**Note:** If the password is wrong, you cannot go to Program Mode from Operation Mode. Therefore, careful attention should be paid to password change. When you forget the password, please contact the local distributor.

# Chapter 5 Digital Communication

The FLOMOTION 900 provides RS232/385 digital communication interface function as an option.

The kinds of data and its format are as follows

## **Output Format**

1. Level Data  
Output level data in ft
2. Flow Rate Data  
Output flow rate data in gal/m
3. Total Flow Data  
Output total flow data in gal

## **Output Data Format**

ASCII edits data and the following is its sequence

LF	CR	L	E	:	9.999	f	t			F	R	:	1234567.89	g	a	l	/	m			
T	F	:	123456789.12			g	a	l													

1. Baud Rate is 9600BPS.
2. 1 Data Frame is composed of 47 byte
3. Data Frame outputs on a second basis.
4. LE : Level data, composed of 5byte, The unit is m.  
ex) 1.234 → 1.234 ft  
FR : Flow Rate data, composed of 10 byte, the unit is gal/m.  
ex) 1234567.89 → 1234567.89 gal/m  
TF : Total Flow Rate, composed of 12 byte, the unit is gal.  
ex) 123456789.12 → 123456789.12 gal

## **Chapter 6 Maintenance**

FLOMOTION 900 does not require any special maintenance. However, in areas where there is a lot of floating matter or viscous sludge, the sensor's surface may be contaminated. Therefore, for accurate measurement, it may be necessary to clean the sensor face if these conditions occur.

# Chapter 7 Menu Option Record

## FLOMOTION 900

	MENU	RANGE	FACTORY SET	1	2	3	4
01	SW VERSION						
02	DIVICE SELECTION		Parshall 2"				
03	AUTO BOTTOM ZERO	-	-				
04	BOTTOM DISTANCE	0.30~4.00	3.936ft				
05	FLOW INDEX	0.00-2.00	6.51ft				
06	4mA POINT SET	0.00 ~ max	0.00				
07	20mA POINT SET	0.00 ~ max	536.00gal/m				
08	RELAY1 ON POINT	0.00 ~ max	0 gal				
09	RELAY1 OFF POINT	0.00 ~ max	0 gal				
10	RELAY2 ON POINT	0.00 ~ max	0 gal				
11	RELAY2 OFF POINT	0.00 ~ max	0 gal				
12	RELAY SIMULATION	0.00 ~ max	1.00 gal				
13	LOW CUT VALUE	0.00 ~ max	0 gal				
14	HIGH CUT VALUE	0.00 ~ max	5,602.94gal/m				
15	TIME SET	-	-				
16	TOTALIZER SET	9999999.99	0.00				
17	PULSE PERIOD	0.01~1.00	0.10 sec				
18	PULSE VALUE	0.1~100.0	30.0 gal				
19	DATA INTERVAL	1~60 min.	60 min				
20	DATA TRANSFER	-	-				
21	BLANKING	0.25~3.00	1.148 ft				
22	TRANSMIT POWER	1,2,3,4,5	3				
23	OUTPUT DAMPING	1 ~ 4	2				
24	FAIL SAFE CURRENT	3.8/m/21.0	3.8mA				
25	FAIL SAFE TIME	20~999	300Sec				
26	DETECT THRESHOLD	4~15	8				
27	mA OUTPUT TEST		HOLD				
28	FLOW RATE FACTOR	.001~1.999	1.0				
29	SYSTEM ID	0~9	0				
30	MASTER RESET	RESET/EXIT	EXIT				
31	PASSWORD CHANGE	0~1000	0				

# < Appendix 1 > Schematic Diagrams of Channels

## A. Parshall Flume

Parshall Flumes are standardized. There are 15 different sizes of Parshall Flumes.

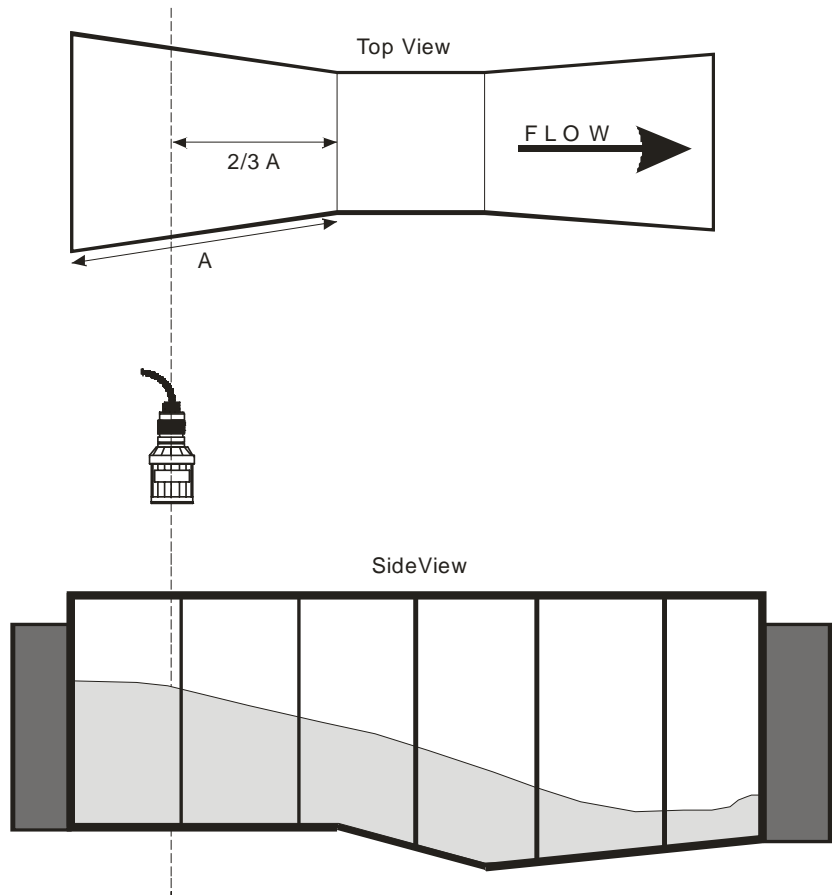

## B. Palmer Bowls Flume

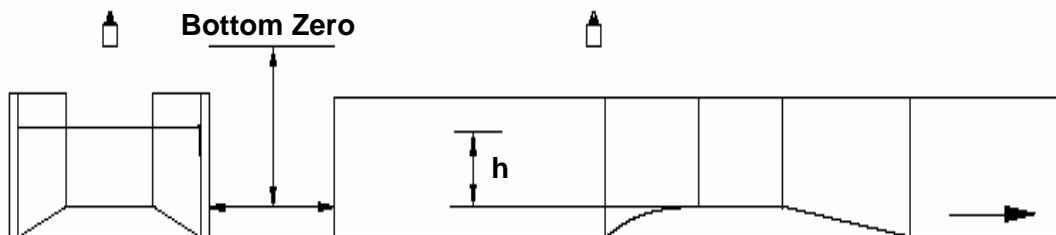

**C.Rectangular Weir, V-notch Weir, Suppressed Rectangular Weir, and Cipolletti Weir**

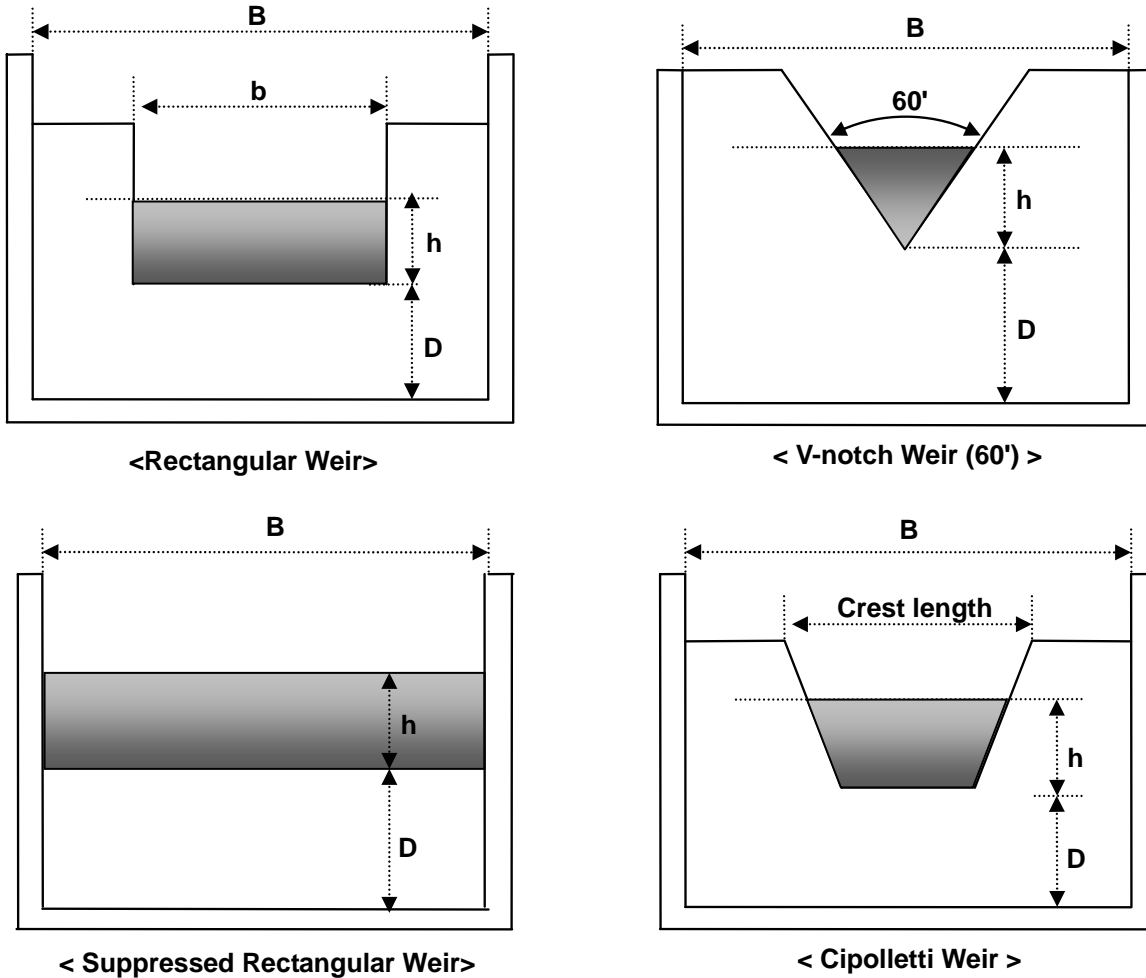

**<Fig. B-1 > Front Views of Weirs**

**h : Water level**

**B : Suppressed Rectangular Weir's Width (ft)**

**b : Rectangular Weir's Width (ft)**

**D : Distance from Weir's Bottom (ft)**

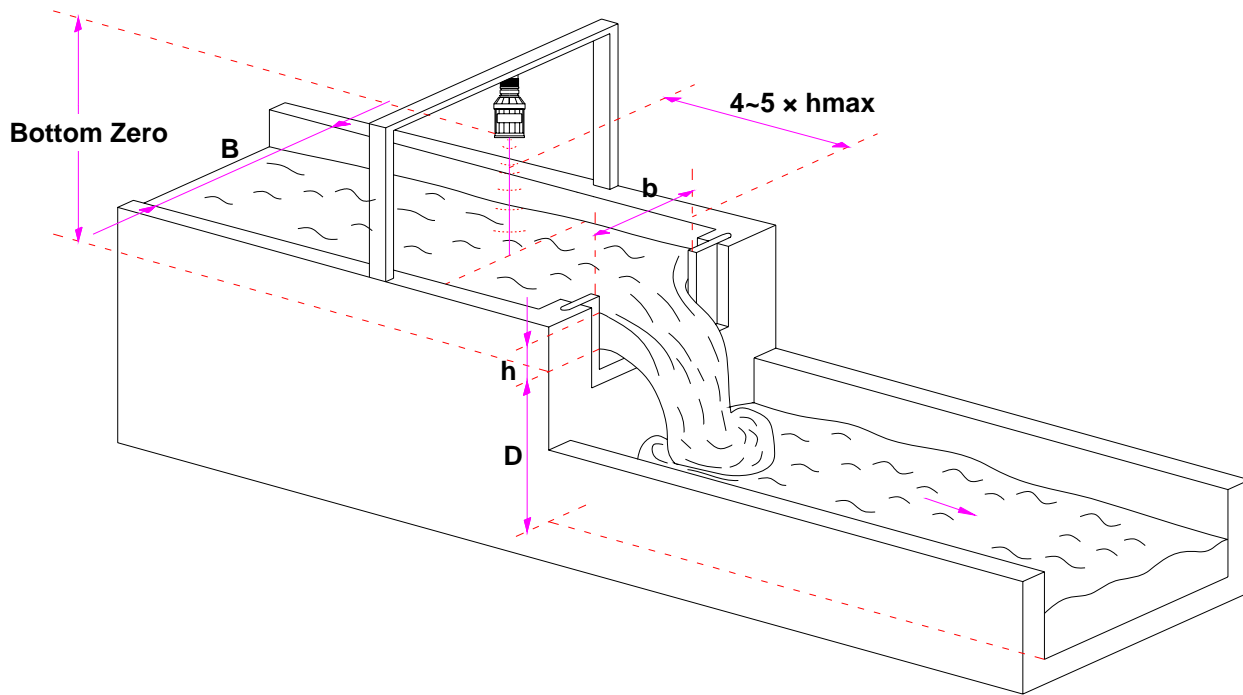

<Fig. B-2 > Top View of Rectangular Weir

