

ELECTROMAGNETIC FLOWMETER

SENSORS:	MUT 500	MUT 2400
	MUT 1000	MUT 2500
	MUT 1100	MUT 2700
	MUT 2200	MUT 2770

with

CONVERTER MC 108

USE HANDBOOK TD 144 ENG



FEBRUARY 2000

SYMBOLS MEANING



WARNING: please refer to the concerning documentation enclosed with the goods



WARNING: electric shock danger

Operations with this symbol must be performed by skilled technicians only

* * *

THE SECTIONS OF THIS OPERATING MANUAL THAT MUST NECESSARILY BE READ BEFORE INSTALLING THE FLOWMETER ARE:

page	paragraph	subject
10	7.2	Liquid direction inside the sensor
11	7.4	Grounding
22	12.1.C1	Connections between converter and sensor (for separate version only)
30	12.1.D	Grounding of the housing
31	12.1.E	Network connection
32	12.3	Data display choice

IT IS ALSO NECESSARY THAT YOU VIEW THE

PRESETTINGS SHEET

HANDED ALONG WITH THE FLOWMETER.

THERE, YOU WILL FIND THE MAIN PARAMETERS VALUES SET IN FACTORY.

PLEASE CHECK CAREFULLY IF THE FOLLOWING MEETS YOUR REQUIREMENTS:

parameters	function
full scale flowrate (f.s.)	01
DN	11
volume per pulse	02

By using the function shown on the second column you may change the relative parameters (see paragraph 12.3.3).

INDEX

	pag.
SYMBOLS MEANING	2
THE SECTIONS OF THIS MANUAL THAT <u>MUST NECESSARILY BE READ</u>	2
INDEX	3
The sensor - preliminary informations	5
1 - MUT 500	5
2 - MUT 1000	5
3 - MUT 1100	6
4 - MUT 2200	7
5 - MUT 2400	7
6 - MUT 2500	8
7.1 - sensor installation	9
7.2 - Liquid direction inside the sensor: how to make sense of the double arrow	10
7.3 - Other rules for a correct installation	10
7.4 - grounding	11
8 - MUT 2700 - Insertion magnetic flow meter	13
8.1 - summarized description of the structure of the MUT 2700	13
8.2 - the component parts	13
drawing D027E0: separate version - overall dimensions	plates
drawing D028E0: compact version - overall dimensions	plates
8.3 - Assembly on pressurized pipes	14
drawing D094D: orientation of electrodes axis	15
8.4 - The penetration of the sensor inside the pipe	16
8.5 - Disassembly of the meter	16
8.6 - Grounding the meter	16
9 - MUT 2770 - Insertion magnetic flow meter	17
drawing D046C0513 compact version - overall dimensions	plates
drawing D012D0127 separate version - overall dimensions	plates
10 - Installation of insertion magnetic flow meter	18
11 - Piping pressure minor than atmospheric pressure: sensors operating	19
12 - CONVERTER MC 108	20
12.1 - INSTALLATION	20
12.A) COMPACT VERSION	20
12.B) SEPARATE VERSION	20
12.1.C - ELECTRICAL CONNECTIONS	22
12.1.C1 - connection between converter and sensor	22
12.1.C2 - NOTE	23
12.1.C3 - connection between converter and sensors MUT 500 and MUT 1100	23
12.1.C4 - Basic connections	23
12.1.C5 - ON/OFF outputs	23
12.1.C5.1 - Totalizer/frequency output	25
12.1.C5.2 - Alarm output	26
12.1.C5.3 - hardware alarm output	27
12.1.C6 - reset input / totalizers stopping	27
12.1.C7 - standard interface RS 485	28
12.1.C8 - ADDITIONAL MODULES	28
Module 2 - 3 - 4 terminal board	29
Module 5 - 6 - 7 terminal board	30

12.1.D - GROUNDING OF THE HOUSING	30
12.1.E CONNECTION TO THE MAIN	31
12.1.F - FUSE	31
12.2 PROGRAMMING OF MC 108 CONVERTER	32
12.2.1 - USE OF THE KEYBOARD	32
12.3 - SELECTION OF THE TYPE OF DATA TO BE DISPLAYED	32
12.3.1 - Alarm display	33
12.3.2 - Data and time display	33
12.3.3 - Parameter display or modification	33
12.4 - THE ENTRY OF A NEW NUMERICAL DATUM	33
12.5 - THE ENTRY OF OTHER DATA	33
12.6 - EXAMPLES OF PROGRAMMING	34
12.7 ACCESS LEVELS AND RESPECTIVE ACCESS CODE KEY	35
12.8 - CONFIGURATION FUNCTIONS AVAILABLE - TABLE	36
APPENDICE 1: TRANSFORMATION FROM COMPACT TO SEPARATE VERSION	49
Instructions to separate MC 108 from the sensor table D111B0529	plates
APPENDICE 2: THE MEANING - OPERATION - PROGRAMMING METHODS FOR A NUMBER OF FUNCTIONS	50
A2.1 - FUNCTIONS 05 (RESPONSE DELAY) 38 (MAXIMUM VARIANCE) 39 (RESPONSE SPEED THRESHOLD)	50
A2.2. - FUNCTION 10 (FACTORY PRE-SETTING)	52
A.2.3 - FUNCTION 14 (OUTPUT SIGNAL TYPE)	52
A2.4. - FUNCTIONS 17 (DUAL RANGE) 18 (AUTORANGING)	54
A2.5. - FUNCTIONS 20 and 21 (CURRENT RANGE/FREQUENCY EXTENSION)	55
A2.6. - FUNCTIONS 45 and 46 (MALFUNCTION CURRENT/FREQUENCY VALUE)	55
A2.7. - FUNCTIONS THAT REGARD THE "EMPTY TUBE" CIRCUIT	56
A2.8 - FUNCTION 47 (AUTOMATIC ZERO-SET CALIBRATION)	57
A.2.9 - FUNCTION 81 - FLOW RATE SIMULATION	57
APPENDICE 3: ERROR OR ALARM MESSAGES VISUALIZED ON THE	58
APPENDICE 4: INCONVENIENCES AND SOLUTIONS	60

The flowmeter, whose this operating manual refers, satisfies the Standard EN 50082-2 (immunity) and EN50081-2 (emission) and belongs to class A.

THE SENSOR - PRELIMINARY INFORMATION

Electromagnetic flowmeters are composed of:

the *sensor* that must be mounted between two portions of pipe by flanges, threaded joints or triclamp joints;

the *converter* that can be mounted on the sensor (compact version) or nearby (separate version); in this case it is connected to the sensor by two cables C012 and C013.

This manual relates to the following sensor models:

1 - MUT 500

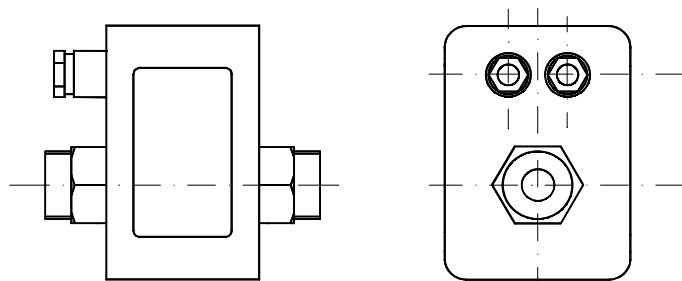

Body and joints in AISI 316 (joints in hastelloy, on request)

threaded male UNI 338 (NPT on request)

Available diameters: DN 3-6-10-15-20 mm

Lining in PTFE (white)

Pressure: standard PN16 (others on request)

2 - MUT 1000 (WAFER)

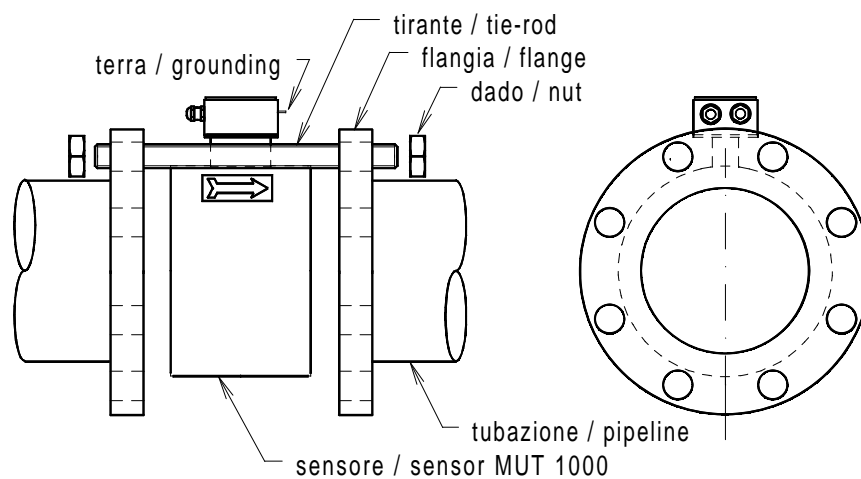

Available diameters from DN 40 to DN 300

Installed between two counterflanges (see tab. 1)

Tight by threaded tie-rods (see tab.1)

Lining in PTFE (white)

3 - MUT 1100 (WAFER)

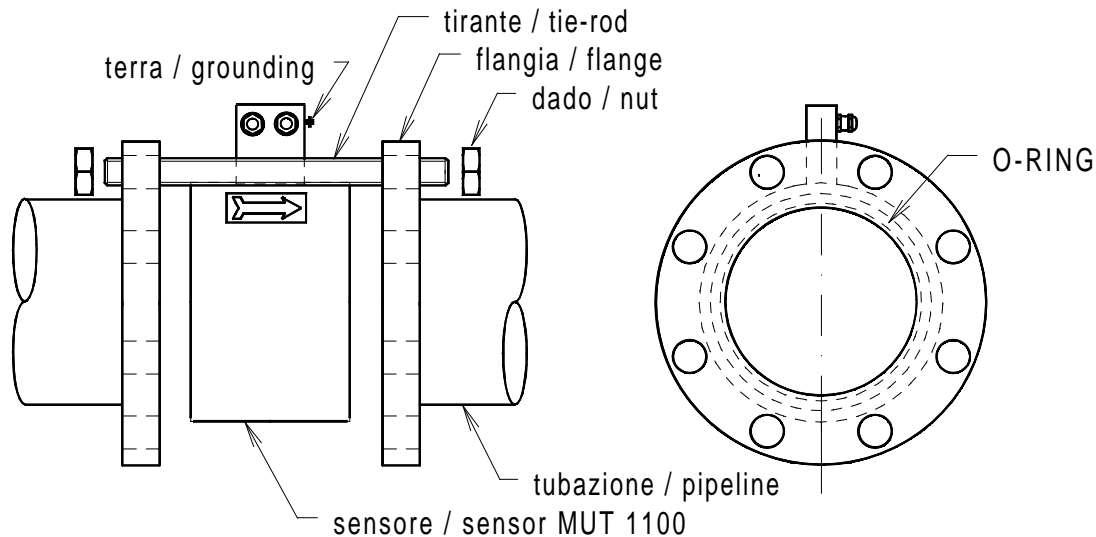

Available diameters from DN 40 to DN 200

Installed between two counterflanges (see tab. 1)

Tight by threaded tie-rods (see tab.1)

Lining in polypropilene

Table 1

DN		USABLE FLANGES, DIAMETERS						-RODS				sensor length	
mm	"	PN16		PN25		PN40		ANSI150		ANSI300		MUT 1000	MUT 1100
40	1"1/2	M16	4	M16	4	M16	4	no	---	3/4"	4	100 mm	100 mm
50	2	M16	4	M16	4	M16	4	no	---	5/8"	8	100 mm	100 mm
65	2"1/2	M16	4	M16	8	M16	8	no	---	3/4"	8	150 mm	150 mm
80	3	M16	8	M16	8	M16	8	no	---	3/4"	8	150 mm	150 mm
	3"1/2	---	---	---	---	---	---	5/8"	8	3/4"	8	150 mm	150 mm
100	4	M16	8	M20	8	M20	8	5/8"	8	3/4"	8	150 mm	150 mm
125	5	M16	8	M22	8	M22	8	3/4"	8	3/4"	8	180 mm	180 mm
150	6	M20	8	M22	8	M22	8	3/4"	8	3/4"	12	180 mm	180 mm
200	8	M20	12	M22	12	M27	12		8		12	200 mm	200 mm
250	10	M22	12	M27	12	M30	12		12		16	250 mm	----
300	12	M22	12	M27	16	M30	16		12		16	300 mm	----

4 - MUT 2200

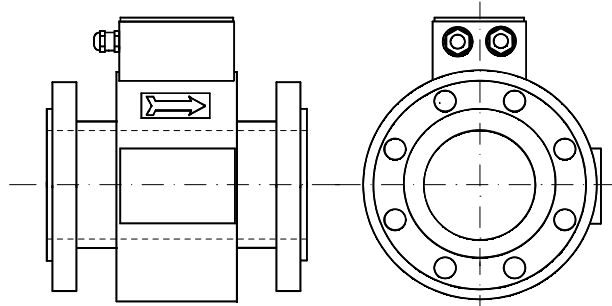

Flanged joints.

Available diameters from DN 25 to DN 400

Lining standard: PTFE (white) (DN 25...150)
 ebonite for food stuffs (black) (DN 200...400)

Pressure standard: 50 PN 40
 PN10 = PN16;
 DN 200... 400 PN16
 PN 25, PN40, ANSI 150. ANSI 300 on request
 PN 64 ebonite lining on request.

Body and flanges in stainless steel on request.

5 - MUT 2400

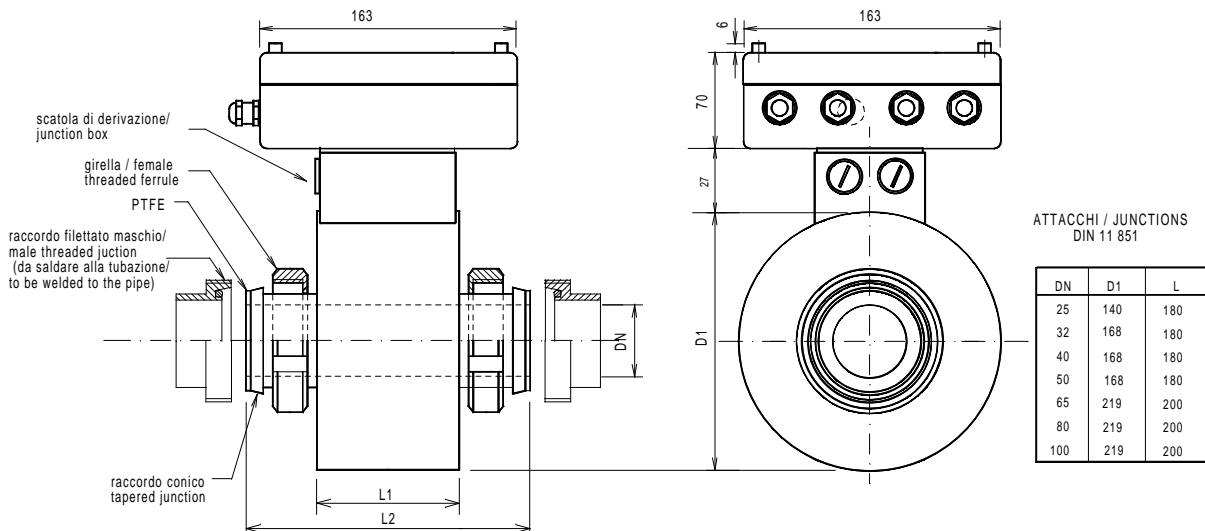

Threaded male joints DIN 11851 or tri-clamp
 Body in AISI 304.
 Available diameters from DN 25 to DN 100

Lining standard: PTFE (white)
 Pressure standard: PN25 DN 25...50
 PN16 DN 65-80-100

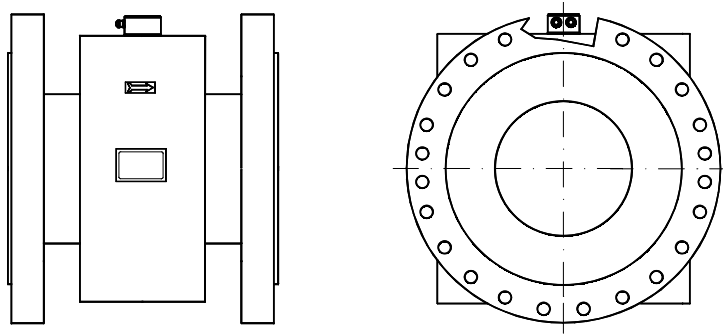
6 - MUT 2500

Flanged joints

Available diameters from DN 450 to DN 2000

Lining standard: ebonite for foodstuffs (black)
on request PTFE (white)

Pressure standard: PN16

PN 25, PN40, PN 64, ANSI 150, ANSI 300 on request:

Body and flanges in stainless steel on request.

* * *

The characteristics above listed are standard.
The characteristics concerning your sensor are shown
on the data plate that we suggest to read carefully

7.1) SENSOR INSTALLATION

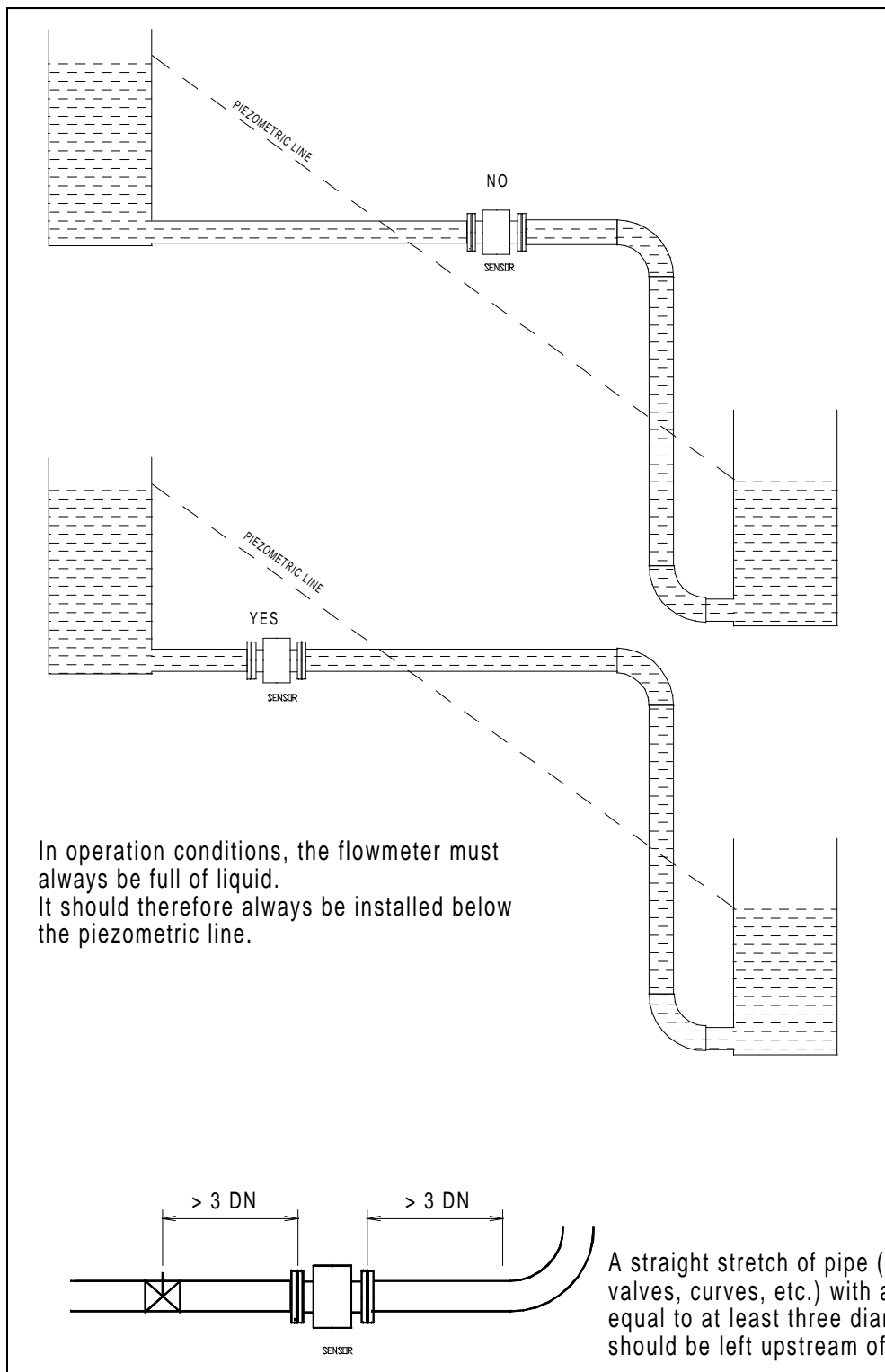

7.2 - LIQUID DIRECTION INSIDE THE SENSOR:
HOW TO MAKE SENSE OF THE DOUBLE ARROW

If the liquid inside the sensor runs following the arrow direction with the - symbol, then the flowrate is negative and a negative number is displayed.

If the liquid inside the sensor runs following the arrow direction with the + symbol, then the flowrate is positive and a number with no sign is displayed.

reverse flowrate
minus sign



forward flowrate
no sign

7.3 - OTHER RULES FOR A CORRECT INSTALLATION

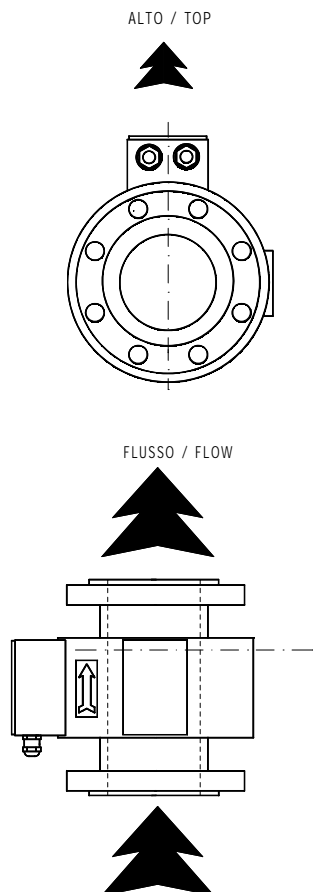

If the meter is mounted on a horizontal pipe, the converter (or junction box) must be mounted above.

If the meter is mounted on a vertical pipe, the liquid must flow from the bottom up.

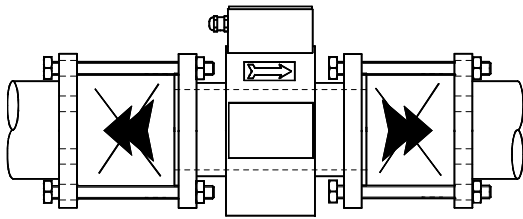

When mounting the meter between pipe counterflanges, do not attempt to bring the two halves of the pipe closer together by tightening the bolts. This would merely damage the meter and invalidate the guarantee.

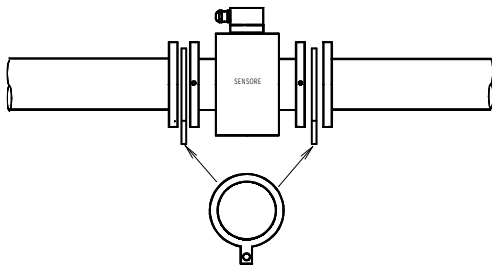

If the pipe is made in insulating material, two metallic earthing rings must be inserted between the meter and the counterflanges.

7.2 - GROUNDING

MAKE THE EARTH CONNECTIONS AS SHOWN IN THE FIGURES S1, S2, S3. WITHOUT THESE CONNECTIONS, THE FLOWMETER DOES NOT WORK.

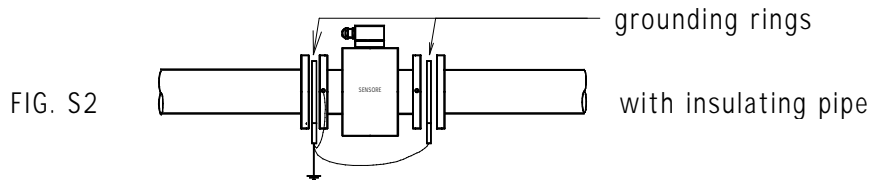
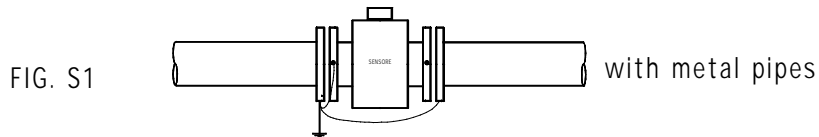
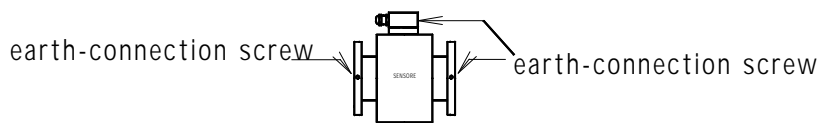

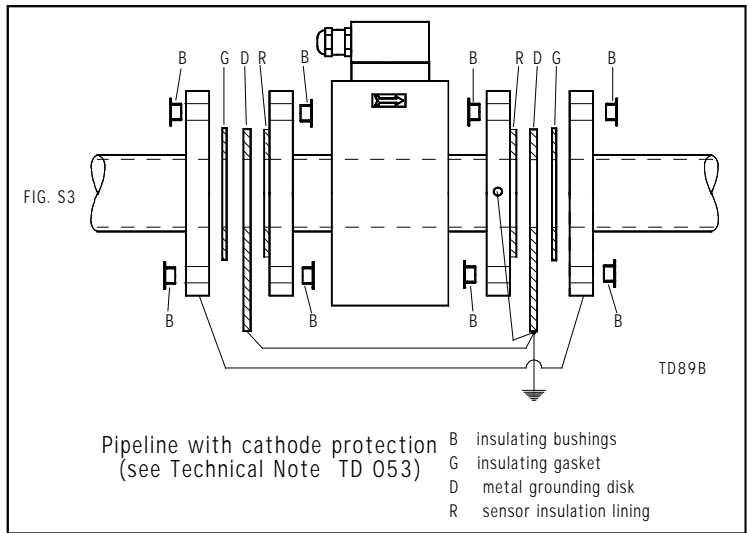

8 - MUT 2700 - INSERTION MAGNETIC FLOW METER

(see drawing D027E0 and D028E0)

This instrument can be installed in pipes with a maximum pressure of 1600 kPa (16 bar).

Installation operations can be performed with the pipe under pressure.

The constructive principle ensures that the sensor is not expelled by the pressure in order to reduce the risk of injury to people in the area and the release of fluid.

For this reason, the installation instructions provided below must be scrupulously respected.

The ball valve supplied permits both the installation and the removal of the meter under pressure.

8.1 - SUMMARIZED DESCRIPTION OF THE STRUCTURE OF THE MUT 2700 (see drawing D027E0 and D028E0)

A coupling to which the ball valve is screwed has been welded onto the pipe.

A guide (A) is screwed onto the ball valve. A ring nut (B) is positioned at the end of the guide (A).

The sensor slides inside the guide. The sensor is composed of one part (D) with one end in contact with the liquid and a threaded rod (F) where the electronic converter **MC 106 A or the junction box (separate version) is fastened at the end.**

Two holes drilled into the lateral sides of the guide provide access to the threaded ring nut (E1) which, when in contact with the other ring nut (B) by means of a spacer, prevents the sensor from leaving the pipe.

The insertion nut E2, provided with the apposite sensor insertion holders, permits the sensor to be pushed inwards by overcoming the opposing force exerted by the pressure inside the pipe.

8.2 - The component parts are as follows:

Table 2

	Standard parts	Accessories for assembly under pressure
1	Sensor complete with sliding guide and junction box (separate version) or electronic converter MC 106 A or MC 106 B (compact version)	
2	2" female coupling, 40 mm long	
3		2" ball valve with male attachment on one end and female attachment on the other
4		Insertion nut E2
5		Sensor insertion holders

8.3 - MUT 2700: ASSEMBLY ON PRESSURIZED PIPES (see Drawing D027E0 and D028E0)

8.4

- 1) Weld the 2" female coupling (N) onto the pipe. The welding seam must be performed only on the outside and free of all interruptions and holes.
- 2) Screw the ball valve (V) down tightly onto the coupling and wind teflon tape around the threading to ensure a perfect seal.
- 3) Drill a hole of at least 49 mm in diameter (centrally aligned in respect to the valve passage hole) in the pipe by introducing a tool that ensures the appropriate seal through the valve.
- 4) Remove the tool while simultaneously closing the valve in order to prevent liquid from exiting.
- 5) Pull the sensor's rod (F) out from the guide (A) as far as possible by rotating the ring nut (E1) **and the insertion nut E2 until they come into contact with the element D.**
- 6) **Screw the sensor insertion holders into the apposite housings on nut E2.**
- 7) **Adjust the sensor position inside the guide A so that the PTFE sensor head is placed inside the guide (to avoid that, when opening the ball valve, the electrodes support might be damaged).**
- 8) **Keeping the valve closed**, install the meter by tightly screwing¹ the guide A onto the valve (winding teflon tape around the threading to ensure a perfect seal).
- 9) Open the valve.
- 10) **Rotate the insertion nut clockwise and move little by little the ring nut E1 so that it may always be visible from the hole of the guide A.**
If the pressure inside the pipe is very high (always < 16 bar) then the sensor may tend to rotate round itself, obstructing the penetration. In this case you should hold the sensor fast either keeping steady the clamping plate under the converter or the connection box (in case of separate version).
- 11) After the desired degree of sensor penetration inside the pipe has been reached (see paragraph 8.4):
 - a) rotate the sensor so that the smaller side of the converter case is parallel to the pipe axis (if the sensor is mounted separated from the converter, proceed as shown in drawing D094D);
 - b) tighten the ring nut E1 to the nut E2. **Once tightened, it serves the following purposes:**
 - 1) to keep the sensor's penetration distance fixed
 - 2) to prevent rotation **of the sensor**

¹ **Never work directly on the converter's case! Use a 36 mm box wrench on the **hole in the guide A.****

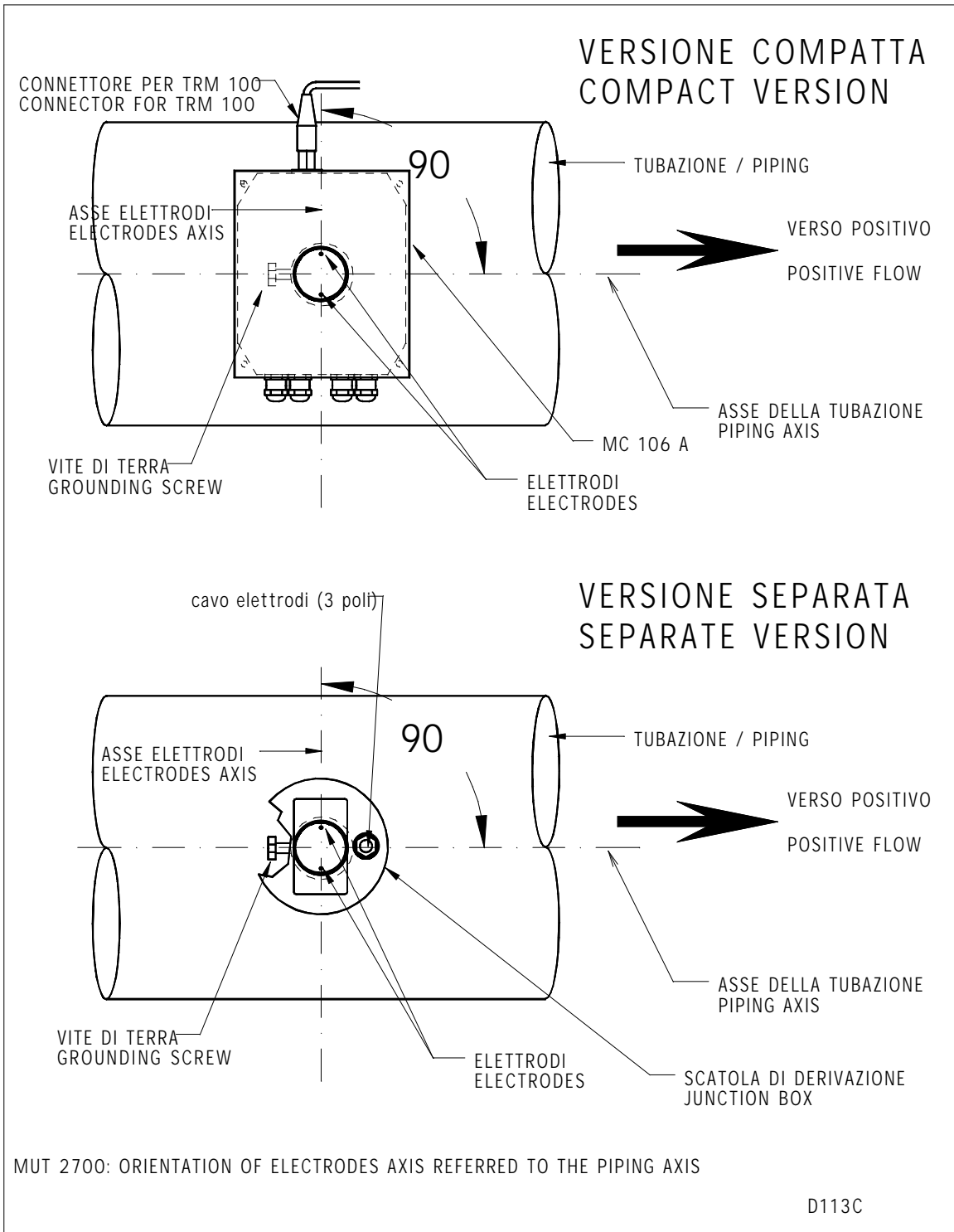

12) **Srew off the insertion holders and put them in a safe place.**

NOTE:

It is obvious that in case you need adjusting the sensor penetration, you should previously re-assembly the sensor insertion holders and then act alternatively on the ring nut E1 and the insertion nut E2.

8.4 - MUT 2700 - THE PENETRATION OF THE SENSOR INSIDE THE PIPE

(See drawing **D027E0 - D028E0**)

The penetration of the sensor inside the pipe must bring the plane of the electrodes to a distance of 1/8 of the pipe's minor diameter from the pipe's internal wall.

This position can be reached by bringing L4 to the following value:

$$L4 = Ltot - s - Di/8 \text{ (mm)}$$

where:

Di = the minor diameter of the pipe in mm

s = the pipe thickness (in mm)

Ltot = the value obtained from column 6 of the table in the respective drawing.

8.5 - MUT 2700 - DISASSEMBLY OF THE METER

8.5.1 - Perform the operations above in inverse order starting from Point 12). **Rotate anticlockwise the insertion nut E2** until the L5 value exceeds the measurement of (Ltot - 16) mm.

8.5.2 - **Close the valve** and unscrew the guide (A) from the valve.

8.6 - MUT 2700 - GROUNDING THE METER

Connect the flow meter to a good grounding by using the suitable screw bolt placed on the converter support (H element, see drawing **D027E0 - D028E0**).

9 - MUT 2770 - INSERTION MAGNETIC FLOW METER

9.1. This instrumentation can be installed in pipes with a maximum liquid pressure of 1600 kPa (16 bar).

9.2. For the installation it is necessary that the pipe is empty.

9.3. Make a 49 mm diameter circular hole on the pipe.

9.4. Weld to the pipe hole a flanged coupling with the following features (see drawing D046C0513):

- a) pipe DN 50 (2") PN 16
- b) flange UNI 2278 DN 40
- c) coupling axis must be perpendicular to the piping axis

S4)

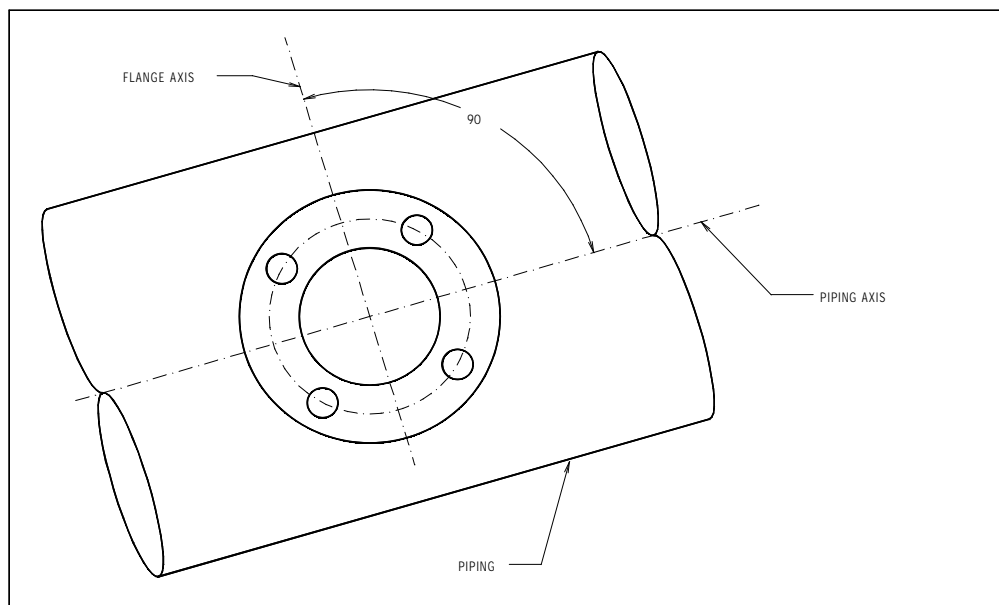

fig. S4

e) respect L10 quote for coupling length. On drawing D046C0513 or D012D0127 is explained the meaning and value of L10.

Suggestion for the pipe internal diameter D_i measurement:

1. Measure by a little rope the external piping circumference (in mm)
 2. Divide this measure for 3,14
 3. Subtract from the result the doubled thickness "s" (in mm) of the piping
- The result obtained is the D_i value in millimeters.

9.5. Insert the flow meter in the coupling (check the O-RING presence on the flange) so that the straight line passing through the two electrodes is perpendicular to the piping axis.

9.6. Press together the two flanges by four Φ 16 MA bolts of 60 mm length.

9.7. Grounding: join to a good ground connection the appropriate bolt placed on the flow meter flange.

10 - INSTALLATION OF INSERTION MAGNETIC FLOW METER

As reminded above the piping must be completely full of liquid, so it is necessary to take the suitable precautonal measures in the choice of the sensor location.

The insertion flow meter requires, in addition, to have a straight lenght piping upstream and downstream without any obstacles. We suggest a lenght of 10 diameters upstream and 5 diameters downstream.

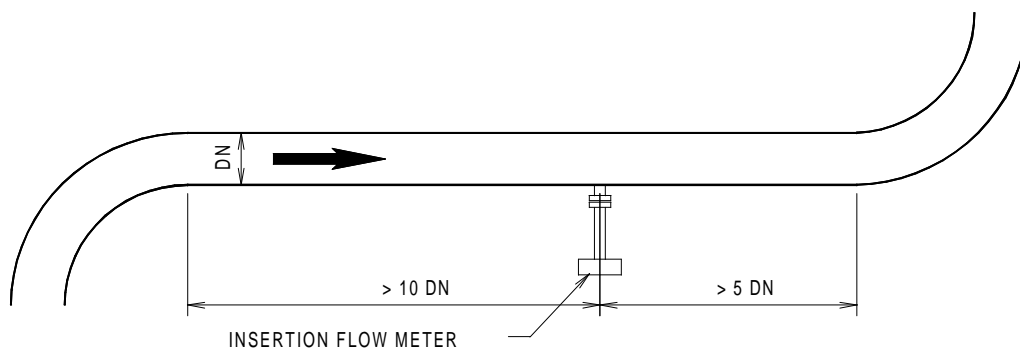

Fig. S5

11 - PIPING PRESSURE MINOR THAN ATMOSPHERIC PRESSURE:

SENSORS OPERATING

If the magnetic flow meter is installed on a piping with a inside pressure sometimes minor than atmospheric pressure (total pressure < 100 kPa = 1000 mbar) it is necessary to check out that the lining is able to resist to these working conditions.

The following table gives/shows the acceptable minimum absolute pressures under of which there could be some problems in the electrodes tightness.

These minimum values depend, as it is easy to understand, on the diameter, on the lining type and on the liquid temperature.

Table 3: VACUUM RATING in absolute mbar ACCEPTABLE inside the sensors

DN	MODEL	LINING			
3...20	MUT 500	PTFE	0	----	0
3...20	HS 300	PTFE	0	0	0
25...80	MUT 2200	PTFE	0	0	130
25...80	MUT 2400	PTFE	0	250	400
40...80	MUT 1000	PTFE	0	250	130
40...80	MUT 1100	POLIPROP.	0	0	----
100...150	MUT 2200	PTFE	150	250	400
100	MUT 2400	PTFE	250	350	500
100...150	MUT 1000	PTFE	150	250	400
100...150	MUT 1100	POLIPROP.	0	0	----
200	MUT 1000	PTFE	200	300	400
250	MUT 1000	PTFE	300	400	500
300	MUT 1000	PTFE	400	500	600
200	MUT 2200	EBANITE	0	0	----
250	MUT 2200	EBANITE	0	0	----
300	MUT 2200	EBANITE	0	0	----
350	MUT 2200	EBANITE	0	0	----
400	MUT 2200	EBANITE	0	0	----
----	MUT 2700	----	300	300	----
----	MUT 2770	----	300	300	----

12 - THE MC 108 CONVERTER

12.1. INSTALLATION

12.1A) Compact version

1 - If the sensor must be installed in v
direct reading of the display.

* Remove the two screws V1 and V2 (Fig. 1).

* Re-insert and tighten the two screws V1 and V2 removed previously.

ires).

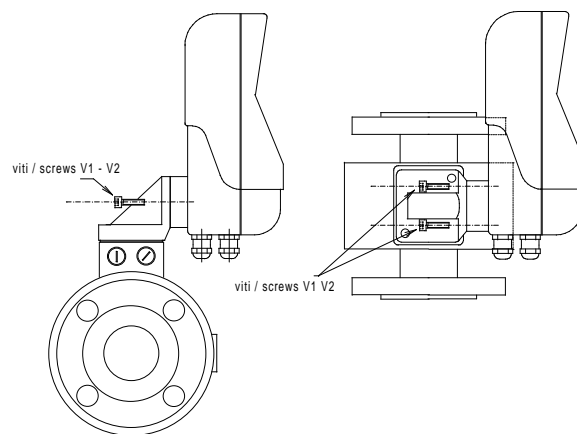

Fig. 1

12.1B) Separate version

B1 - Coupling

- Read the instrument's rating plate
- Read the number punched in the ACCOP./COUPLING box.
- This is the serial number of the sensor with which this converter must be coupled.
- If no number has been punched into the ACCOP./COUPLING box, the converter can be coupled to any our company sensor at all.

12.1B2 - The converter can be installed on the wall or on the target rod. For this reason it comes supplied with a plate with two 6 mm holes on the rear (see Fig. 2).

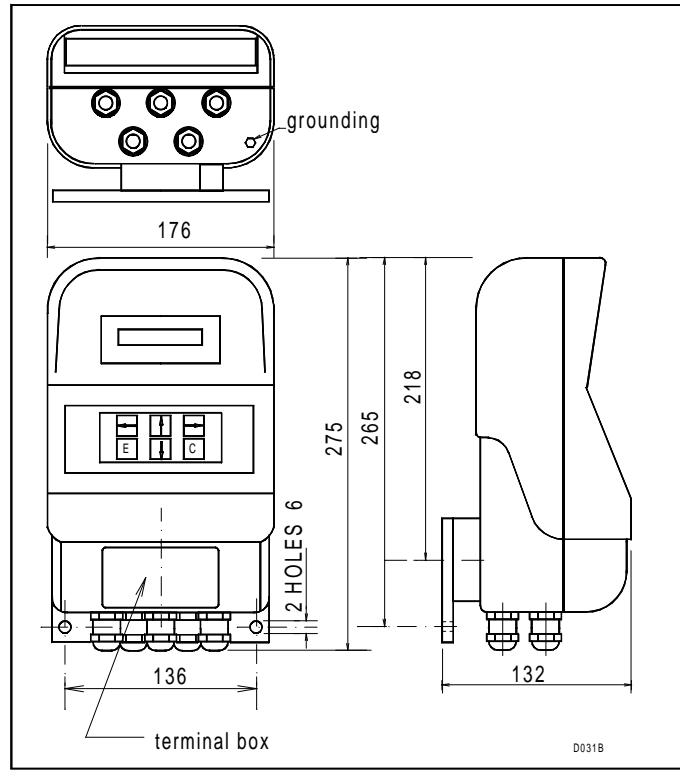

Fig. 2

12.1.C) ELECTRICAL CONNECTIONS



The access to the connection box is allowed to skilled technicians only.

The access to the connection box is possible by screwing off the four screws (3 mm).

Fig. 3 shows the connection board of the main board and the function of each terminal. The following diagrams show the single connections in a more detailed way.

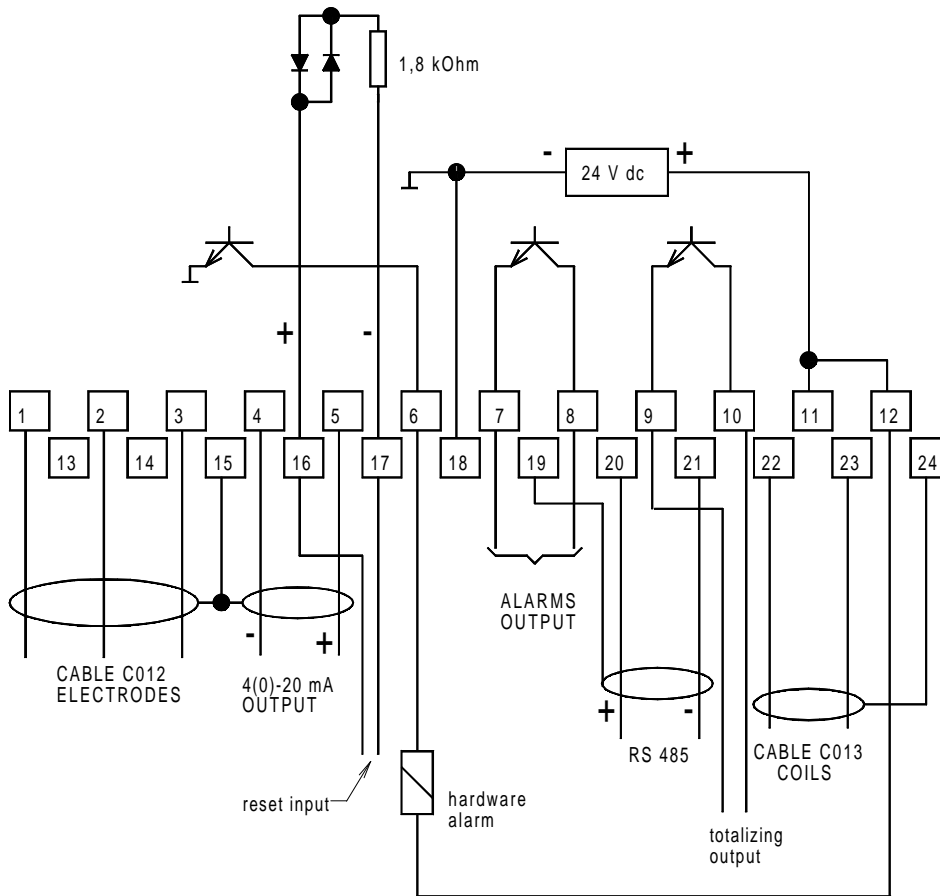

Fig. 3



12.1.C1 - Connection between converter and sensor.

The connection between converter and sensor is made by the two cables C012 and C013 following carefully the instruction illustrated in fig. 4

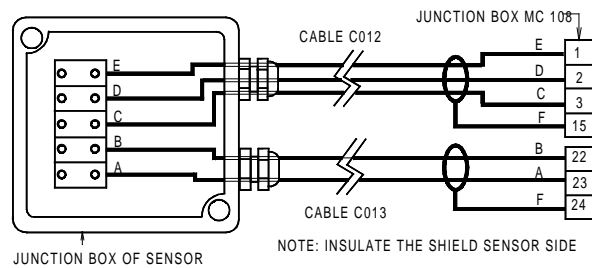

Fig. 4

NOTE

The sensor connection box is suitable to grant a protection degree IP 68 for a permanent immersion of the sensor with a head of water of 4 metres.

It is plain that this result may be really obtained only if, after the the cables connection, the two cable glands and the two screws closing the housing were suitably fastened.

In order to avoid possible faults during these operations, we suggest two possible solutions:

I	II
We can supply the sensor with the cables already connected and with the connection box full of sealing resin .	We can supply a packet of sealing resin SIP1 suitable to fill up the connection box, after a corretct cables connection work.



In any case, before connecting the meter to the power supply electrical network you must close the connection box with its cover.

12.1.C3 - Connections of sensor MUT 500 and MUT 1100 to the converter.

Sensors MUT 500 and MUT 1100 are supplied with cables C012 and C013 already connected. In their free ends, these cables are equipped with small rings marked with some characters which will help the connection to the converter, according to diagram of fig. 4.

12.1.C4 - BASIC CONNECTIONS

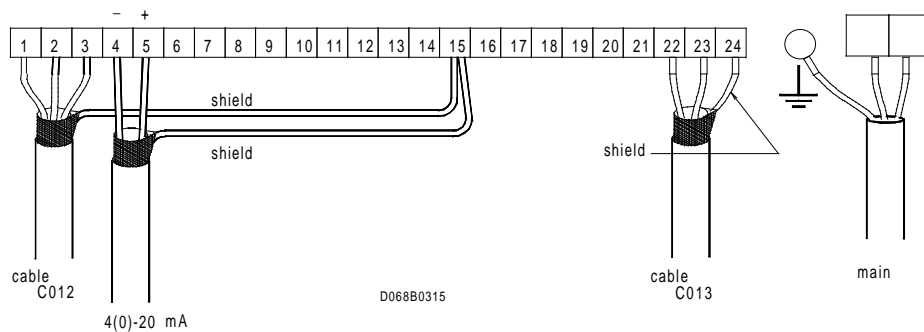

Fig.5

Fig. 5 shows the connections of cables C012 and C013 (for the separate version only) (fig. 4) of current output 4 (0) - 20 mA of power supply

12.1.C5 - ON/OFF OUTPUTS

Three on/off output are available in the basic version.

	COLLECTOR	EMITTER
TOTALIZING / FREQUENCY OUTPUT	terminal 10	terminal 9
ALARMS OUTPUT	terminal 8	terminal 7
HARDWARE ALARM OUTPUT	terminal 6	to the "minus" of the power supply

To these outputs several kind of receivers may be connected. In fig. 6 we summarize the main connection types.

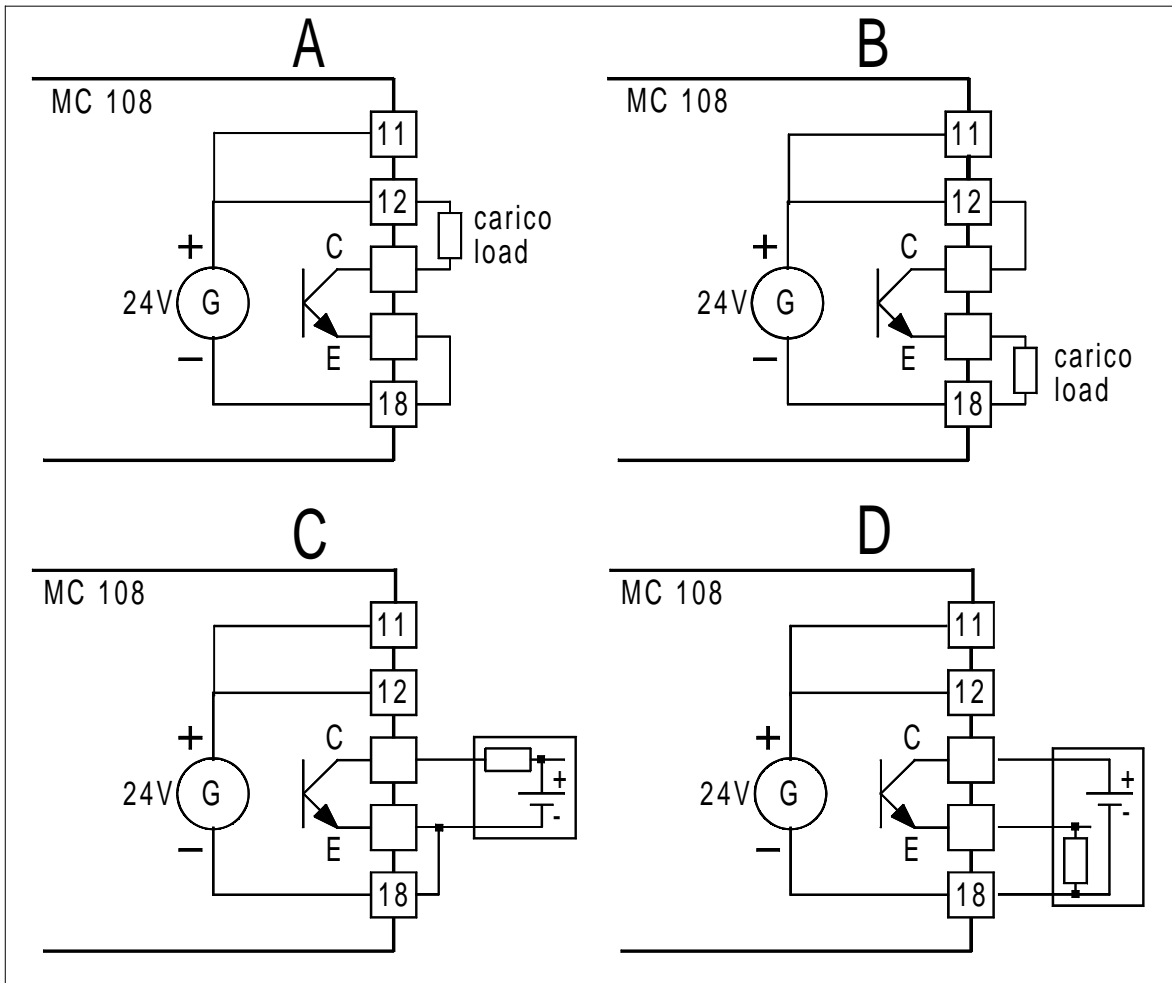

Fig. 6

If you have to use this output for an impulse counter or an electromechanical pre-selector (24 Vdc) it must be connected as in A (remember the connection between emitter E and terminal 18) or as in B (remember the connection between collector C and terminal 12).

The "load" indicated in diagram A and B may be an electromechanical pulse counter (24 Vdc) or a 24 Vdc relay.

If you have to use an electronic pulse counter or a PLC with a supplied input, you may use one of the diagrams C or D.

Diagrams A and C: maximum frequency = 12500 Hz.

Diagrams B and D: maximum frequency = 2500 Hz.

12.1.C5.1 - TOTALIZER / FREQUENCY OUTPUT

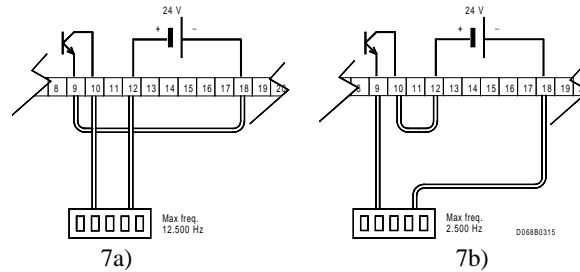

Fig. 7

Fig. 7 shows two possible connections of a pulse counter or of an electromechanical presetter.

As an alternative it is possible to use an electronic pulse counter (for the connections see the pulse counter data sheet) (see NOTE 1 pag. 28).

The connection **7a** (common emitter) allows to reach 12.500 Hz; the connection **7b** (common collector) allows to reach 2500 Hz only.

Any way, for a correct functioning of the pulse counter always remember that:

Between clamps 12 and 18 there are 24 Vdc; the schemes above described use 24 Vdc pulse counter.

Presetting the parameters influencing the maximum generable frequency, keep in mind the fitness of the chosen pulse counter to work at that frequency.

These parameters are defined by the following presetting FUNCTIONS:

FUNCTION 2 - presetting of the volume V_1 corresponding to 1 pulse

FUNCTION 3 - presetting of the width t_1 of 1 pulse

FUNCTION 4 - presetting of the full scale frequency

FUNCTION 14 - choose: frequency output (proportional to the full rate) **or** pulse output (one pulse each volume V_1 passed)

When, by the FUNCTION 14, the device is preset for frequency output it automatically sets the pulse width. It results to be, at any frequency f :

$$t_1 = 1000 / 2 f \quad [\text{milliseconds}] \quad (1)$$

otherwise, when the device is preset for pulse output, the width t_1 is set by FUNCTION 3.

Named: Q_{\max} = max full rate (litres per second)
 V_1 = volume corresponding to 1 pulse (in litres)
 t_1 = width of 1 pulse (in milliseconds)

the freq f_{\max} that can be reached at the max. full rate is

$$f_{\max} = Q_{\max} / V_1 \quad [\text{pulses per second}] \quad (2)$$

This frequency could not be reached if was input (FUNCTION 3) a too long pulse width t_1 . The maximum width of t_1 that is possible to input in order to reach the frequency given by (2) is

$$t_1 = 1000 / 2 f_{\max} \quad [\text{milliseconds}] \quad (3)$$

When selecting the pulse counter it is necessary to verify:

- a) if it is able to reach the frequency selected as full scale (FUNCTION 14 - frequency output)
or given by (2) (FUNCTION 14 - pulse output)
- b) if it is able to work with a pulse width smaller or equal to value given by (3).

If even only one of these conditions do not verify,

if the output is a frequency output it is necessary decrease the full scale frequency
or
to change pulse counter

if the output is a pulse output it is necessary increase V1
or
to change pulse counter

Examples:

- Frequency output :

Wanting a full scale frequency of 5000 Hz. The pulse counter must be able to work at a maximum frequency a little bit greater than 5000 (safety margin) and with pulses having a width smaller than

$$t_1 = 1000 / 2 f = 0,1 \text{ milliseconds}$$

- Pulse output:

Full rate di f.s. = 27 mc/h = 7,5 litri per second

Wanting 1 pulse each cc (V1 = 0,001 litres

The maximum frequency f_{\max} will be

$$f_{\max} = 7,5 / 0,001 = 7500 \text{ Hz}$$

The pulse width must be smaller or equal to

$$t_1 = 1000 / 2 f_{\max} = 0,06 \text{ ms}$$

The pulse counter must be able to work at more of 7500 Hz and with pulses having a maximum width of 0,06 ms.

12.1.C5.2 - - ALARM OUTPUT

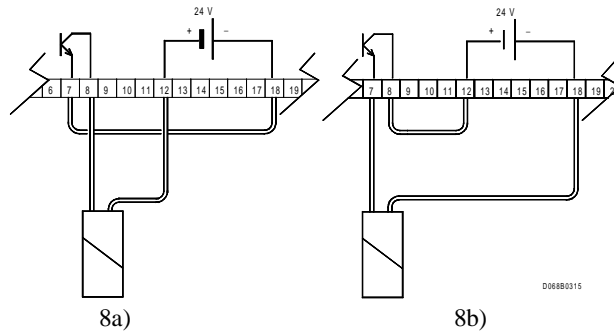

Fig. 8

The transistor of this output (v. NOTE 1) closes when happens one or more of the following conditions:
MAX. FLOW RATE ALARM (enabled by FUNCTION 29, threshold by FUNCTION 40)

MINIMUM FLOW RATE ALARM (enabled by la FUNCTION 30, threshold by FUNCTION 41)

EMPTY TUBE ALARM (enabled by FUNCTION 31)

OVERFLOW ALARM (enabled by FUNCTION 32)

If no one of these four functions is enabled, the transistor is on when the flowrate is reverse.

12.1.C5.3 - HARDWARE ALARM OUTPUT

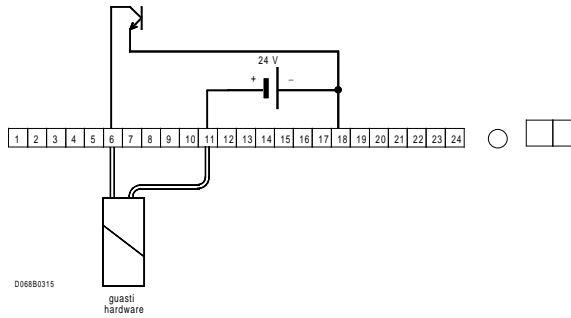

Fig. 9

A relay (24 Vdc; I < 100 mA) connected between clamps 6 and 18 opens when converter, coils or cables failures occur (V. NOTE 1 pag. 28).

12.1.C6 - RESET INPUT / INTERNAL TOTALIZERS STOPPING

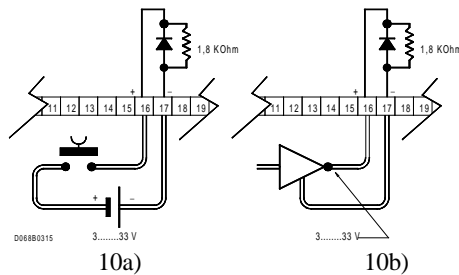

Fig. 10

This input allows the zeroing or the stopping of the internal totalizers (see FUNCTIONS 25 - 26 - 27 - 28 for the zeroing; FUNCTION 75 per the stopping) by a remote control. This command must be a voltage included between 3 and 33 V. The input resistance is 1800 Ohm.

12.1.C7 - STANDARD INTERFACE RS 485

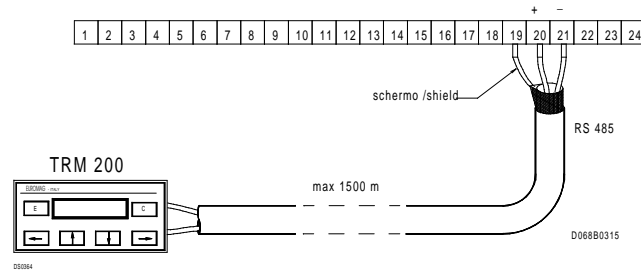

Fig. 11

Between the clamps 20 and 21 (shield on 19) it is available the standard interface RS 485. For example, it may be used, to input and to receive data from the TRM 200 (see data sheet DS034) that may be installed at a maximum distance of 1500 metres (of cable).

* * *

NOTE 1 . The kind of connection depends on the device to which the the converter will be connected. Other kinds of connection are possible, also with external power supply smaller than 24 Vdc: the suggestions of the electrical diagram should allow an electronic technician an easy adaptation to his own requirements.

NOTE 2
 If both ON/OFF and 4-20 mA are not used, **connect the clamp 18 to clamp 15 (or to 24).**

 If the interface RS 485 is not used, **connect the clamp 19 to clamp 15 (or to 24)**

NOTE 3 . The total amount of absorption of the ON/OFF outputs must not exceed the 100 mA.

12.1.C8 - ADDITIONAL MODULES

Fig. 12 and 13 show the connections with the terminals of the additional modules. The available modules are:

module 2	interface RS 232
module 3	interface RS 485
module 4	2 one switch relay; contacts: 5 A 60 V rms
module 5	RS 232 + 2 one switch relay; contacts: 5 A 60 V rms
module 6	RS 485 + 2 one switch relay; contacts: 5 A 60 V rms
module 7	MODEM

MODULE 2: RS 232 INTERFACE

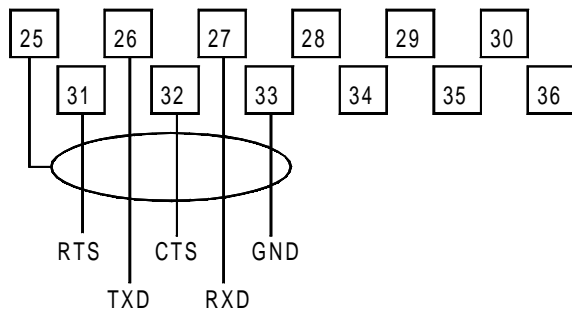

MODULE 3: RS 485 INTERFACE

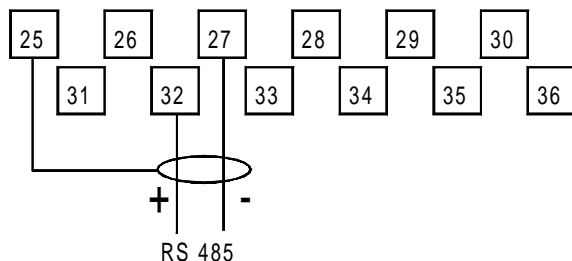

MODULE 4: TWO RELAY

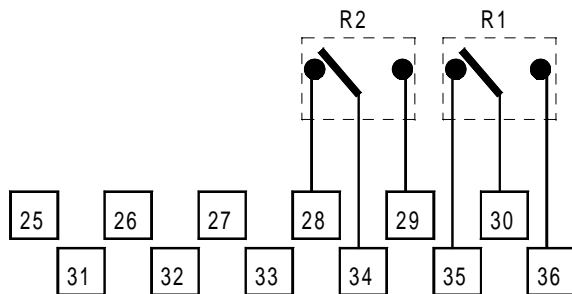

D205B

Fig. 12

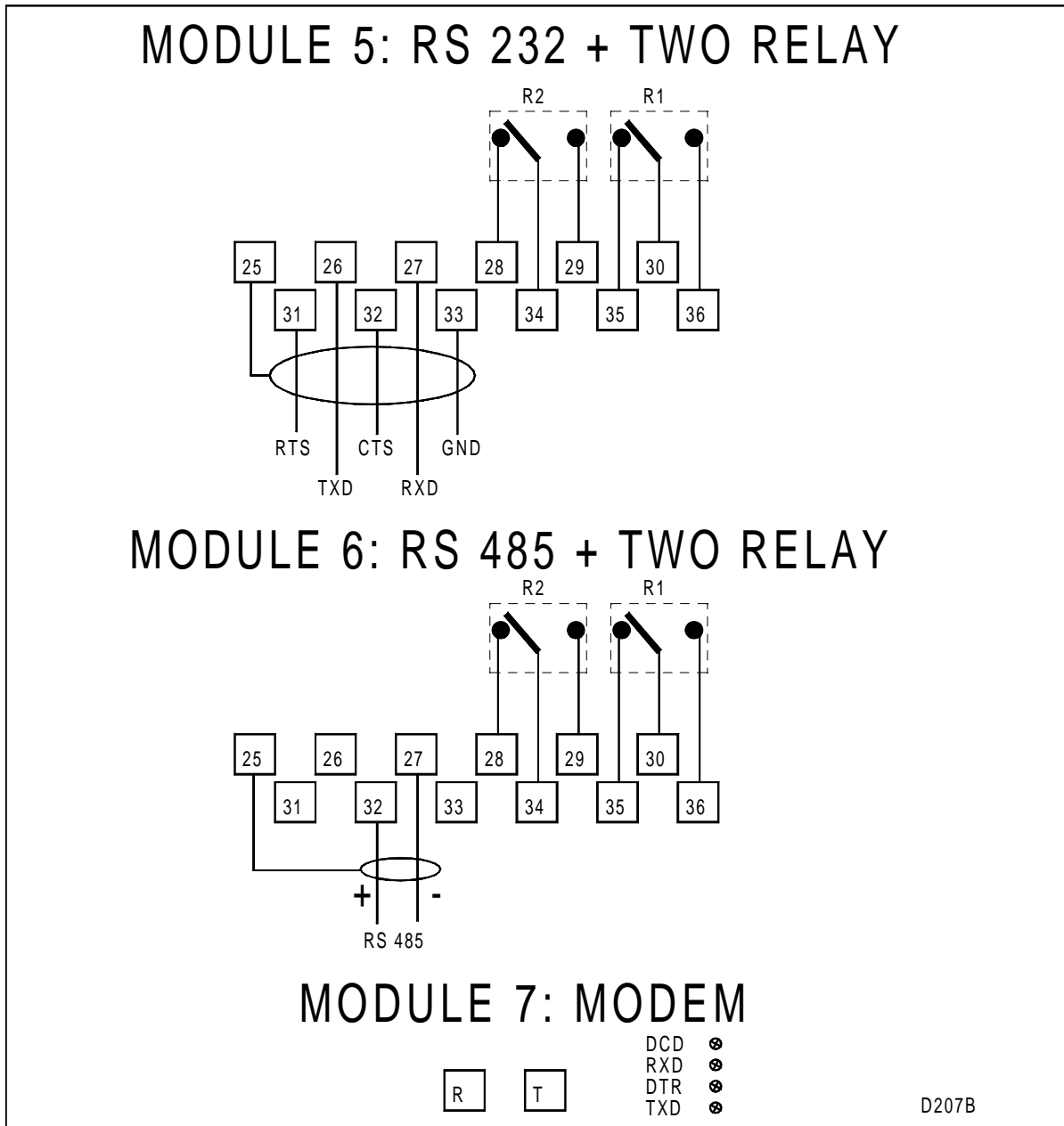

Fig. 13

12.1.D GROUNDING OF THE HOUSING.

The converter housing must be grounded.

It is possible to do by:

- a) grounding the bolt near the cable gland
- b) connecting the grounding wire, when existing, of the power supply cable to the screw set

between the two cable clamps. It is necessary to use a fork terminal (see fig. 5 par. 12.1.C4).

12.1.E - POWER SUPPLY NETWORK CONNECTION

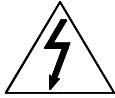

(The operation must be performed by skilled technicians only)

Only after performing all the other connections, you can connect the converter to the network.
On the power supply clamps (Fig. 14) is indicated the voltage:

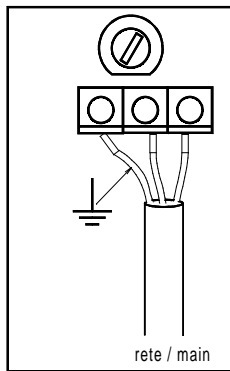

If 90 - 264 Vac is indicated, the device can be fed by voltages from 90 up to 264 V (50...60 Hz)

If 24 V is indicated, the device can be fed by

24 V. The frequency is indifferent

Fig. 14 Power supply

Power supply	90...264 Vac	20,8...27,6 Vac	19...33 Vdc
Main frequency	50/60 Hz	50/60 Hz	-----
Maximum power absorbed	20 W	20 W	20 W
Maximum VA	27,5 VA	25,5 VA	-----
Switch on peak current	max 20 A; 3 ms long	max 35 A; 4 ms long	max 35 A; 4 ms long



12.1.F - FUSE

(In case of need it must be replaced by skilled technicians only)

The fuse is set in the connection box, behind the power supply clamps. It is the 5 x 20 type: 250 V. Its value is

for power supply voltage

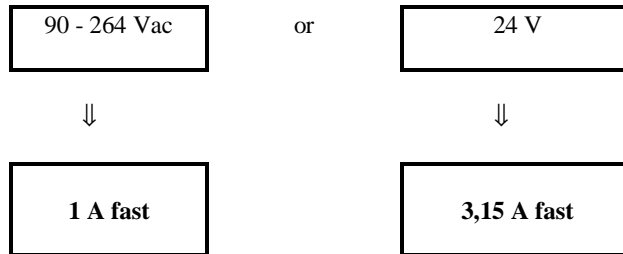

12.2 PROGRAMMING OF MC 108 CONVERTER

12.2.1 - USE OF THE KEYBOARD

The keyboard has 6 keys

(E) = ENTER is used:

- * to confirm data entered
- * to enable the pre-set mode
- * to confirm a "critical" selection (totalizer reset, etc.)

(C) = CLEAR is used:

- * to abandon a function disregarding any modifications made
- * to display an alarm
- * to show the type of data on the display
- * to disable the pre-set mode

(←) and (→) = LEFT and RIGHT are used:

- * to shift the cursor to the digit to be modified
- * to change the data display mode on the display

(↑) and (↓) = UP and DOWN are used:

- * to modify the digit selected by the flashing cursor
- * to make a choice between the range of choices available
- * to change the instrument's reading range (if enabled)
- * to display the date and hour

12.3 - SELECTION OF THE TYPE OF DATA TO BE DISPLAYED

During normal converter operation, the display shows the measurement data in ways that can be configured by the user. The combinations possible are:

1. Flow rate in measurement units and percentage
2. Flow rate in measurement units and total positive flow rate totalizer
3. Flow rate in measurement units and total negative flow rate totalizer
4. Flow rate in measurement units and partial positive flow rate totalizer
5. Flow rate in measurement units and partial negative flow rate totalizer
6. Positive flow rate total and partial totalizer
7. Negative flow rate total and partial totalizer
8. Positive and negative flow rate partial totalizer

The LEFT and RIGHT arrow keys are used to change the type of data display, and the display will show the selection made.

Press (C) to see all the flow rate or volume data requested.

Press (E) to check the data and to save the setting selections made.

If (C) is pressed while the display is showing flow rate or volume, the current type of data display will be shown. Press (C) again in order to return to the display of flow rate data.

12.3.1 - ALARM DISPLAY

The appearance of the ">! <" or "!" symbols signifies that one or more alarm causes are present. By pressing (C), the display shows the most important alarm cause among all those detected. Press (C) again in order to see the flow rate or volume data.

12.3.2 - DATE AND TIME DISPLAY

The current date and hour are displayed by pressing the UP and DOWN keys. Function No. 48 must be used to set the date and time. The internal clock does not have its own batteries and cannot function without electrical power supply. The date and time are "frozen", however, whenever the instrument is switched off, and this provides an indication of how long the instrument has been switched off (for tax-related and other types of verification purposes). Press (C) again in order to see the flow rate or volume data.

12.3.3 - PARAMETER DISPLAY OR MODIFICATION

Pressing the (E) key grants access to parameter display or modification functions. The 5-digit access key must be entered (Function No. 00) in order for data modification to be performed. Press (C) again in order to see the flow rate or volume data.

12.4 - THE ENTRY OF A NEW NUMERICAL VALUE

Whenever a new numerical value must be entered, the display may read as follows, for example:

Line 1: PARAMETER NAME - name of the parameter to be entered
 Line 2: UNIT 000.0_ - unit of measurement and value to be modified
 The "_" symbol indicates the cursor.

At this point, the LEFT and RIGHT arrow keys are used to shift the cursor to the digit to be changed, while the UP and DOWN arrow keys are used to change the digit's value.

When the new numerical value has been set, press either (E) to enter the new value or (C) to cancel the operation.

12.5 - THE ENTRY OF OTHER DATA

Non-numerical data, such as the type of output mode: PULSE or FREQUENCY, must also be set on the instrument. The display will appear as follows when these selections must be made:

Line 1: PARAMETER NAME name of the parameter to be entered
 Line 2: CHOICE X_ - one of the many selections possible
 The "_" symbol indicates the cursor.

Use the [] and [] arrow keys in order to scan all the choices possible for such parameter. After the desired choice has been made,

press either (E) in order to confirm the choice made,
 or (C) to cancel the operation.

12.6 - EXAMPLES OF PROGRAMMING/SETTIN UP

In order to modify device parameters it is necessary to introduce a access code (see paragraph 12.7). This code enable **programming level 1**, assigned for most frequently used functions and remain operative for all modifies duration: **it is not necessary, therefore, introducing it for every function to be modified**. The programming level come back to zero after two minutes if other keys on the keyboard are not pushed. When the flow meter goes out from our factory the pre-set code has the following value:

10800

It is possible to modify this code by using function 74 (PERSONAL CODE).

EXAMPLE 1: Input of accesscode (in this example: 10800)

NOTES: The sym
 The sequence of operations described is from left to right and from the top to the bottom.

line	KEY	on the DISPLAY	NOTES
1	[E]	process data (flow rate, volumes, ecc..)	The programming mode is now enabled
2	[E]	ACCESS LEV.0 FUNCTION N.v 0	Enable function 00, which permits the introduction of an access code
3	[]	ACCESS CODE PASSWORD: v 0000	Increase the first access code figure (in this case 10800)
4	[\]	ACCESS CODE PASSWORD: v 0000	By this key the cursor moves to the second code figure
5	[\]	ACCESS CODE PASSWORD: 1v 000	The cursor positions on the third figure
6	[] 8 times	ACCESS CODE PASSWORD: 10v 00	The third figure increases until reaching number
7	[E]	ACCESS CODE PASSWORD: 10v 00	By pressing this key the code is introduced
8		ACCESS LEV.1 FUNCTION N. v 0	Now programming level 1 is enabled and is indicated on the display

Now that programming level 1 is enabled it is possible to pass to the following example.

EXAMPLE 2: modify of full scale from 5.0000 l/s to 10.000 m³/h

line	KEY	on the DISPLAY	NOTES
9	[\]	ACCESS LEV.1 FUNCTION N. v 0	By this key the cursor moves to the figure closer to the right of the function number
10	[]	ACCESS LEV.1 FUNCTION N.0v	By this key the figure closer to the right increases
11	[E]	ACCESS LEV.1 FUNCTION N.0v	Function 01, which permits to modify the full scale, is now enabled
12	[]	F.S. FLOW RATE l / s v .0000	= seconds)
13	[]	F.S. FLOW RATE l / v 18000	The cursor moves over volume unity (in this
14	[] 4 times	F.S. FLOW RATE v / h 18000	
15	[\] 3 times	F.S. FLOW RATE mv / h 18.000	Bring the cursor over the second figure of flow value
16	[] 8 times	F.S. FLOW RATE m ³ / h 1v .000	
17	[E]	F.S. FLOW RATE m ³ / h 1v .000	By this key the modification made is confirmed and the parameter is memorized
18	[C]	ACCESS LEV.1 FUNCTION N. v 1	By this key the modification is finished and process data are visualized/displayed again
19		process data (flow rate, volumes, ecc..)	The modification is finished and on the display there are the new process data expressed in the new measurement units

12.7 - ACCESS LEVELS AND RESPECTIVE ACCESS CODE KEY

LEVEL 0: Parameter display - no access code required.

LEVEL 1: Primary parameter modification - ACCESS CODE: **10800** (can be modified by user)

LEVEL 2: Secondary parameter modification ACCESS CODE **21600** (fixed)

A 5-digit code must be entered in order to obtain access to the various levels. The Level 1 code can be modified by the user; the others are fixed. In order to gain access to higher levels, the Level 1 code must first be entered, and then the access code for the next level must be entered.

The request for access codes can be eliminated by configuring the PERSONAL ACCESS CODE (FUNCTION 74) to a value of 00000. After 2 minutes of keyboard inactivity (in which no keys are pressed), the level of enabling returns to zero.

12.8 - CONFIGURATION FUNCTIONS AVAILABLE

NF = NO. OF FUNCTION

L = ACCESS LEVEL

MOD. = OPTIONAL MODULE REQUIRED FOR THE RESPECTIVE FUNCTION

0 = NO ADDITIONAL MODULE IS REQUIRED FOR THE FUNCTION.

N.F	L	OPZ	DISPLAY	NOTE
00	0	0	ACCESS CODE	Access code for function
01	0	0	F.S. FLOW RATE	full scale flow rate and measurement unit selection
02	0	0	IMPULSE VOL. UNIT	Totalizer pulse volume and measurement unit
03	0	0	IMPULSE WIDTH	Totalizer pulse duration
04	0	0	FREQUENCY RANGE	Frequency field proportional to flow rate
05	0	0	RESPONSE DELAY	Response delay (time constant)
06	1	0	RESET TOTAL. +	TOTAL DIRECT: Totalizer zero-setting
07	1	0	RESET TOTAL. -	TOTAL INVERSE: Totalizer zero-setting
08	1	0	RESET PARTIAL +	PARTIAL DIRECT: Totalizer zero-setting
09	1	0	RESET PARTIAL -	PARTIAL INVERSE: Totalizer zero-setting
10	1	0	RECALL DEFAULTS	Factory default data loading
11	2	0	NOMINAL DIAMETER	Rated diameter of sensor/pipe
12	2	0	COEFF. KA	Sensor coupling coefficient "A" (field)
13	2	0	COEFF. KB	Sensor coupling coefficient "B" (zero)
14	2	0	OUTP SIGNAL MODE	Digital output signal: pulse/frequency
15	2	0	DISPLAY SAMPLE RATE	Display frequency on display
16	2	0	MAINS FREQUENCY	Power supply mains frequency
17	2	0	DUAL RANGE	Dual range measurement range
18	2	0	RANGE CHANGED BY	Autorange
19	2	0	CURRENT OUTP. RANGE	Current range (0-20 / 4-20 mA)
20	2	0	C. OUTP.OVERRANGE	Current field extension (up to 22 mA)
21	2	0	FREQU. OVERRANGE	Frequency field extension (+25%)
22			NOT AVAILABLE	
23	2	0	TOTALIZING MODE	Totalization mode (unidirectional/bi-directional)
24	2	0	EMPTY PIPE TEST	Empty test tube
25	2	0	TOTAL + EXT.RESET	TOTAL DIRECT zero-setting on ext. input
26	2	0	TOTAL - EXT.RESET	TOTAL INVERSE zero-setting on ext. input
27	2	0	PARTIAL + EXT.RESET	PARTIAL DIRECT zero-setting on ext. input
28	2	0	PARTIAL - EXT.RESET	PARTIAL INVERSE zero-setting on ext. input
29	2	0	FLOW MAX. ALARM	MAX. ALARM AND OUTPUT enabling
30	2	0	FLOW MIN. ALARM	MIN. ALARM AND OUTPUT enabling
31	2	0	EMPTY PIPE ALARM	EMPTY TUBE ALARM OUTPUT enabling
32	2	0	OVERRANGE ALARM	OUT-OF-RANGE/RANGE CHANGE ALARM enabling
33	2	0	TOTALIZ. DECIMALS	Number of decimals for totalizer display
34	2	0	LAYOUT LANGUAGE	Language used for messages
35	2	0	SELF-CALIBRATION	Automatic calibration enabling interval
37	2	0	FLOW LOW CUT-OFF	Totalization threshold (CUT-OFF)
38	2	0	PEAK SUPPRESSION	Max. flow rate variation threshold (PEAK CUT)
39	2	0	RESPONSE SPEED	Measurement response speed threshold
40	2	0	FLOW MAX ALARM	MAX. alarm threshold
41	2	0	FLOW MIN ALARM	MIN. alarm threshold
42	2	0	ALARM HYSTERESIS	Alarm threshold hysteresis value

43	2	0	FLOW UNIT TYPE	Flow rate measurement unit selection
44	2	0	VOL. UNIT TYPE	Volume measurement unit selection
45	2	0	FAULT COND. CURR.	4-20 mA current value in case of malfunction
46	2	0	FAULT COND. FREQ.	Frequency value in case of malfunction
47	2	0	AUTOZERO ADJ.	Automatic zero-setting calibration
48	2	0	DATE AND TIME	Time and date setting
49	2	0	SAMPLING TIME	Time interval for measurement acquisition and printing
50	2	0	DATA LOGGER	Data acquisition enabling (DATA LOGGER)
51	2	0	SAVED DATA TYPE	Selection of type of data to be acquired
52	2	0	RESET DATA LOGGER	Acquired data zero-setting
53	2	0	DATA LOGG. EMPTY	Acquired data display (if present)
60	2	4,5,6	AUX. 1 OUTPUT	AUX. 1 output function selection
61	2	4,5,6	AUX. 2 OUTPUT	AUX. 2 output function selection
62	2	0	RS485 BUS ADDR.	RS485 address
63	2	0	RS485 SPEED	RS485 speed
64	2	2,3,5,6	COMM2 SPEED	Extra serial speed
67	2	2,5	ENERGY SAVING	Enabling reduction of energy consumption
68	2	0	LINEARIZ. POINTS	
68	2	2,5	RINGS METER/COUNTER	MODEM automatic answer
69	2	0	LINEARIZ. COEFF.	
69	2	2,5	DISCONNECTION	number for MODEM call
70	2	2,5	TELEPHONE NUMBER	MODEM connection interruption
71	2	2,5	DATA PRINTING	Data print enabling
72	2	2,3,5,6	RX/TX RE-SENDING	Data re-transmission mode enabling
73	2	0	E.PIPE AUTO ADJ.	Empty tube signal regulation
74	2	0	USER PASSWORD	Personalized access code
75	2	0	TOTALIZZ. LOCKING	Totalizer shutdown enabling with RESET on
77	2	0	E.PIPE PULSE W.	Empty tube test pulse duration
78	2	0	E.PIPE THRESHOLD	Empty tube detection threshold
79	2	0	SPECIFIC WEIGHT	Specific weight for measurement unit
81	2	0	FLOW SIMULATION	Flow rate simulation value
82	2	2,5	CONFIG. PRINTING	Instrument configuration print

MODULES SPECIFICATION

module	SPECIFICATION
0	No module installed
2	RS232 module
3	RS485 module
4	AUX1 and AUX2 on/off output module
5	RS232 module + AUX1 and AUX2 outputs
6	RS485 module + AUX1 and AUX2 outputs
7	MODEM module

FUNCTION 01: FULL RANGE FLOW RATE

Minimum access level: 0; 1 to modify

The full range flow rate can be set in the following units:

Metric

Volume	Weight
cm ³ = 0.001 dm ³	g = 0.001 kg
ml = 0.001 dm ³	hg = 0.1 kg
dm ³ = 1 dm ³	kg = 1 Kg
l = 1 dm ³	q = 100 Kg
dal = 10 dm ³	t = 1000 Kg
hl = 100 dm ³	
m ³ = 1000 dm ³	

Non-metric

Volume		weight	
	dm ³		kg
in ³ , cubic inches	1.63871e-2	oz, once	0.028350
oz UK, fl.oz UK	0.02841	lb, libbre	0.45359
oz US, fl.oz US	0.02597	ton, short ton	907.18
pt UK, pints UK	0.5679		
pt US, pints US	0.4731		
qt UK, quarts UK	1.1359		
qt US, quarts US	0.9462		
gal UK, gallons UK	4.545771		
gal US, gallons US	3.785333		
ft ³ , cubic feet	28.31685		
bbbl, std barrel	119.238		
bbbl oil, oil barrel	158.984		
yd ³ , cubic yards	764.555		

The time units possible are: seconds (s), minutes (m), hours (h), and days (d).

The full range flow rate can be set between 4 and 100% of the max. flow rate value (equivalent to a speed of the liquid of 10 meters/second).

If a dual range has been enabled, the low flow rate must be set subsequently.

FUNCTION 02: TOTALIZATION PULSE VOLUME

Minimum access level: 0; 1 to modify

The totalization pulse volume can be set in the units of measurement listed above and in a numerical range of from 0.00001 - 99999.9.

The measurement unit used to set the pulse volume will also be used to display the totalizer counts.

FUNCTION 03: TOTALIZATION PULSE DURATION

Minimum access level: 0; 1 to modify

The totalization pulse duration can be set as desired in the range of 0.04 and a maximum of 9999.99 milliseconds.

The tolerance value is 0 to -20 microseconds.

The output transistor must be connected to a common emitter with the load on the collector in order to obtain the maximum output frequency.

FUNCTION 04: FREQUENCY FIELD

Minimum access level: 0; 1 to modify

Whenever output in frequency has been selected instead of pulse, this function permits the setting of the instrument's full range frequency in a range of between 10.00 and 10,000.00 Hertz.

FUNCTION 05: RESPONSE DELAY

Minimum access level: 0; 1 to modify

The response delay values permitted (in seconds) are 0.18300.0. This value represents the digital filter's time constant.

FUNCTION 06, 07, 08, 09: TOTALIZER ZERO-SETTING

Minimum access level: 1

The following totalizers can be zero-set with the use of these functions:

- * DIRECT TOTAL FLOW RATE (FUNC. 06)
- * INVERSE TOTAL FLOW RATE (FUNC. 07)
- * DIRECT PARTIAL FLOW RATE (FUNC. 08)
- * INVERSE PARTIAL FLOW RATE (FUNC. 09)

A request for confirmation is made before zero-setting is performed.

FUNCTION 10: FACTORY PRE-SETTING

Minimum access level: 1

With this function it is possible to cancel all the modifications introduced on the parameters and to come back to the standard factory presetting.

FUNCTION 11: SENSOR/PIPING DIAMETER:

Minimum access level: 2.

This function permits the insertion of the nominal diameter in the sensor (plate data): the range is 1÷3000 mm.

If it is a insertion flow meter (MUT 2700 or MUT 2770), you have to input the value (in mm.) of the actual internal diameter of the piping.

If you input value "0" with the insertion meter, the display shows the liquid velocity measure in m/s.

In this case it is possible to associate a full scale value in m/s to the 20 mA value or to the frequency full scale by the 01 function (full scale).

NOTE. When you input a value of "0" as diameter value, the numbers shown by the totalizers have the meter dimensions, but they are useless.

FUNCTION 12: SENSOR COUPLING COEFFICIENT "A"

Minimum access level: 2

This Function permits the sensor's coupling coefficient "A" (read on the rating plate) to be entered in a range of from +0.7500 - +9.9999.

NOTE

If in the data plate the coefficient is preceded by the sign - select the sign - moving the cursor;
if in the data plate the coefficient is preceded by the sign + or there is no sign at all, select the sign + moving the cursor.

FUNCTION 13: SENSOR COUPLING COEFFICIENT "B"

Minimum access level: 2

This Function permits the sensor's coupling coefficient "B" (read on the rating plate) to be entered in a range of from 000000 - 999999.

NOTE

If in the data plate the coefficient is preceded by the sign - select the sign - moving the cursor; if in the data plate the coefficient is preceded by the sign + or there is no sign at all, select the sign + moving the cursor.

FUNCTION 14:OUTPUT SIGNAL TYPE

Minimum access level: 2

This Function permits the setting of an output signal that is proportional to either the flow rate (FREQUENCY) or to the metered duration pulses set with Function 3. The choices are:

- * PULSE
- * FREQUENCY

FUNCTION 15:DISPLAY FREQUENCY

Minimum access level: 2

This Function permits the setting of the number of readings that can be obtained on the display from 1 to 10. This Function affects only the data present on the display and not the real measurements themselves.

FUNCTION 16:MAINS FREQUENCY

Minimum access level: 2

Selections possible:

- * 50 Hz
- * 60 Hz

FUNCTION 17:DUAL READING RANGE

Minimum access level: 2

When this Function is enabled, two measurement reading ranges can be obtained; one range contains the other. The low range permits the expansion of the output field in order to obtain greater resolution.

Exemple

	Low range	Normal range
Flow rate:	0-1 meters/second	1-10 meters/second
Current:	4-20 mA	4-20 mA

Range valid for Normal range: $(Q_{max}/12.5) - Q_{max}$

Range valid for Low range: $(Q_{max}/25) - \text{Normal range Full-Range}$

The switching between a scale and the other one may be made in 4 different ways; see the next function.

FUNCTION 18:RANGE CHANGE

Minimum access level: 2

If Function 17 has been enabled, Function 18 permits the selection of the way in which the measurement scales are exchanged:

1)	On the FLOW RATE VALUE	if $ Q > SB$	normal scale
		if $ Q < SB \times 0.9$	low scale

2)	On the FLOW RATE DIRECTION	if $Q < 0$	low scale
		if $Q \geq 0$	normal scale
3)	From an EXTERNAL INPUT	if the input ≥ 3 Volts	low range
		if the < 3 Volts	normal scale
4)	On the MANUAL CONTROL	UP key	normal scale
		DOWN key	low scale

FUNCTION 19:CURRENT FIELD

Minimum access level: 2

This Function is used to select the current range

* 4-20 mA

* 0-20 mA

FUNCTION 20:CURRENT FIELD EXTENSION

Minimum access level: 2

When this Function has been enabled, the current can reach a value of 22 mA (110% of the 0-20 mA range - 112.5% of the 4-20 mA range); otherwise the range is limited to 20 mA (100%).

FUNCTION 21:FREQUENCY FIELD EXTENSION

Minimum access level: 2

When this Function has been enabled, the frequency (if selected with the use of Function 14) can reach a value of 110% of the full-range set; otherwise the range is limited to 100%.

FUNCTION 23:TOTALIZATION MODE

Minimum access level: 2

If Function 14 has been enabled, totalization pulses can be emitted in two different ways:

* UNIDIRECTIONAL: pulses are emitted only if $Q > 0$ (only positive flow rate)

* BI-DIRECTIONAL: pulses are emitted only if $|Q| > 0$ (positive or negative flow rate)

The internal totalizers make their counts in any case, regardless of the totalization mode selected.

FUNCTION 24:EMPTY TEST TUBE

Minimum access level: 2

When this Function has been enabled, a conductivity measurement is performed between the measurement electrodes. If the threshold has been exceeded, the tube is empty, the measurement on the display returns to zero and the current and frequency outputs go to a pre-set alarm value (which can be modified as per NAMUR NE43).

FUNCTION 25, 26, 27, 28: TOTALIZER EXTERNAL ZERO-SETTING

Minimum access level: 2

These functions enable totalizer reset whenever a voltage > 3 Volt has been applied between Terminals 16-17.

TOTAL DIRECT FLOW RATE	(FUNC. 25)
TOTAL INVERSE FLOW RATE	(FUNC. 26)
PARTIAL DIRECT FLOW RATE	(FUNC. 27)
PARTIAL INVERSE FLOW RATE	(FUNC. 28)

FUNCTION 29: MAX. FLOW RATE ALARM

Minimum access level: 2

This Function permits the max. flow rate alarm to be enabled ($Q > \text{max. threshold}$) and the appropriate output to be enabled when the respective alarm is triggered.

FUNCTION 30: MIN. FLOW RATE ALARM

Minimum access level: 2

This Function permits the min. flow rate alarm to be enabled ($Q < \text{min. threshold}$) and the appropriate output to be enabled when the respective alarm is triggered.

FUNCTION 31: TUBE EMPTY ALARM

Minimum access level: 2

This Function permits the tube empty alarm to be enabled and the appropriate output to be enabled when the respective alarm is triggered.

FUNCTION 32: OVERFLOW ALARM

Minimum access level: 2

This Function permits the out-of-range alarm to be enabled ($|Q| > 100\% \text{ f.s.}$) and the appropriate output to be enabled when the respective alarm is triggered.

FUNCTION 33: TOTALIZER DECIMALS

Minimum access level: 2

From 0 to 3 decimal figures can be set for totalizer reading. The totalizer value is automatically updated.

FUNCTION 34: MESSAGE LANGUAGE

Minimum access level: 2

This Function permits the choice between 2 different languages.

FUNCTION 35: SELF-CALIBRATION

Minimum access level: 2

This Function permits the instrument's automatic calibration (which cancels the gain and conversion offset error). This Function requires an execution time that is 3 times as long as the sampling period. There are 4 self-calibration modes:

- * DISABLED
- * EVERY 10 MINUTES
- * EVERY HOUR
- * AT EXTERNAL COMMAND (input > 3 Volts)

Because a calibration cycle lasts 3 times longer than a normal measurement, we recommend either disabling this Function whenever dosing is performed or using an external command as soon as dosing is begun. This Function is used whenever the meter is subjected to sudden changes in temperature.

FUNCTION 37 CUT OFF (FLOW RATE SUPPRESSION)

Minimum access level: 2

This Function inhibits the totalization of the flow rate whenever $(Q) < \text{the threshold}$. The threshold values are included in the range of 0.0 and 25% of the f.s., value.

FUNCTION 38 PEAK FLOW RATE CUTOFF

Minimum access level: 2

This Function limits the measurements that differ from one another by a set value greater than the threshold value set, and permits the reduction of any components of noise present in the measurement. Valid values: 0 to 125% of the f.s.

FUNCTION 39 RESPONSE SPEED

Minimum access level: 2

This Function permits the measurement filter to be by-passed (response delay) whenever the variations between the two measurements exceed the threshold value set. The values range from 0 to 125% of the f.s..

FUNCTION 40 MAX. FLOW RATE ALARM

Minimum access level: 2

The alarm threshold value ranges from: 0-125% of the f.s.

FUNCTION 41 MIN. FLOW RATE ALARM

Minimum access level: 2

The alarm threshold value ranges from: 0-125% of the F.S.

FUNCTION 42 ALARM HYSTERESIS

Minimum access level: 2

The alarm hysteresis threshold can be programmed from 0 - 25% of the f.s.

FUNCTION 43 FLOW RATE MEASUREMENT UNIT

Minimum access level: 2

This Function permits the selection of the following 4 different combinations:

- METRIC VOLUME
- METRIC WEIGHT
- NON-METRIC VOLUME (BRITISH OR US SYSTEM)
- NON-METRIC WEIGHT (BRITISH OR US SYSTEM)

The specific weight must be entered for the unit of weight (Function 79).

FUNCTION 44 VOLUME MEASUREMENT UNIT

Minimum access level: 2

This Function permits the selection of the following 4 different combinations:

- METRIC VOLUME
- METRIC WEIGHT
- NON-METRIC VOLUME (BRITISH OR US SYSTEM)
- NON-METRIC WEIGHT (BRITISH OR US SYSTEM)

The specific weight must be entered for the unit of weight (Function 79).

FUNCTION 45 MALFUNCTION CURRENT VALUE

Minimum access level: 2

Whenever a hardware alarm has been triggered (tube empty, coils interrupted, etc.) the current output goes to the value programmed with this Function.

Values possible: from 0 to 120% at 20 mA

The NAMUR NE42 Recommendations prescribes a value of < 3.6 mA or > 21 mA.

FUNCTION 46 FAILURE SIGNAL FREQUENCY

Minimum access level: 2

Whenever a hardware alarm has been triggered (tube empty, coils interrupted, etc.) the frequency output goes to the value programmed with this Function.

Values possible: from 0 to 125% of the f.s.

FUNCTION 47 AUTOMATIC ZERO-SET CALIB.

Minimum access level: 2

This Function is used to perform the system's "AUTOZERO" calibration. Make sure that the liquid is perfectly stationary. The UP key is used to enable calibration.

FUNCTION 48 DATE AND TIME SETTING

Minimum access level: 2

This Function is used to set the instrument's date and time. These values are "frozen" whenever the instrument's power supply is cut-off. The subsequent difference between the real time and the time indicated on the instrument permits the interval for which the instrument remained without power to be calculated with precision. The time range valid is as follows: from 00:00 01/01/1992 to 23.59 31/12/2091.

The clock is used by the DATA LOGGER and by the system during automatic printing.

FUNCTION 49 SAMPLING INTERVAL

Minimum access level: 2

This Function permits the setting of the sampling interval in minutes from 1 to 60,000. This interval is used to collect data in the DATA LOGGER or for automatic data printing.

FUNCTION 50 DATA ACQUISITION

Minimum access level: 2

This Function is used to enable data acquisition (in the DATA LOGGER).

FUNCTION 51 TYPE OF DATA

Minimum access level: 2

The operator can choose to collect either flow rate or volume data. A maximum of 64 volume or flow rate samples can be acquired.

FUNCTION 52 DATA ACQUISITION ZERO-SETTING

Minimum access level: 2

This Function is used to set the data acquired by the DATA LOGGER to zero. A request for confirmation is made before zero-setting is performed.

FUNCTION 53 ACQUIRED DATA DISPLAY

Minimum access level: 2

This Function is used to display the data acquired.

FUNCTION 60 AUX. 1 OUTPUT

Minimum access level: 2

This Function is used to select AUX1 output operation as follows (if the extra module has been installed):

DISABLED:	Output always disenergized
LOW FLOW RATE ALARM:	Output energizes if $ Q < \text{min. threshold}$
HIGH FLOW RATE ALARM:	Output energizes if $ Q > \text{max. threshold}$
FLOW DIRECTION:	Output energizes if $Q < 0$ (negative flow)
OUT-OF-RANGE ALARM:	Output energizes if $Q > 100\% \text{ F.S.}$
EMPTY TUBE ALARM:	Output energizes if the tube is empty
MEASUREMENT RANGE:	Output energizes if the low range has been enabled

FUNCTION 61 AUX. 2 OUTPUT

Minimum access level: 2

This Function is used to select AUX2 output operation as follows (if the extra module has been installed):

DISABLED: Output always disenergized
 LOW FLOW RATE ALARM: Output energizes if $|Q| < \text{min. threshold}$
 HIGH FLOW RATE ALARM: Output energizes if $|Q| > \text{max. threshold}$
 FLOW DIRECTION: Output energizes if $Q < 0$ (negative flow)
 OUT-OF-RANGE ALARM: Output energizes if $Q > 100\% \text{ F.S.}$
 EMPTY TUBE ALARM: Output energizes if the tube is empty
 MEASUREMENT RANGE: Output energizes if the low range has been enabled

FUNCTION 62 RS485 ADDRESS

Minimum access level: 2

This Function permits the introduction of the RS485 system address. The values can range from 0 to 31.

FUNCTION 63 RS485 SPEED

Minimum access level: 2

Four different speeds can be selected:

1200 bps
 2400 bps
 9600 bps
 19200 bps

FUNCTION 64 COMM2 SPEED

Minimum access level: 2

If the extra serial module has been installed, four different speeds can be selected:

1200 bps
 2400 bps
 9600 bps
 19200 bps

FUNCTION 67: ENERGY SAVING

Minimum access level: 2

If enabled, this function permits to save up to 70% on energy consumption. This consumption is obtained to the detriment of measure speed sampling, therefore it is suitable only for fairly stable flows. In this way the coils are enabled only for 1/8 of the total sampling cycle. According to the measure pipe it is possible to obtain a reading every 1, 2 or 4 seconds (50 Hz) or every 0.833, 1.67 and 3.33 seconds (60 Hz). When the energy saving is enabled, display lighting is normally disabled, while datas continue to be in the display as well. It is enabled by pressing any key and disabled after 2 minutes of keyboard inactivity.

FUNCTION 68: RINGS METER/COUNTER

Minimum access level: 2

This function is usable only when MODEM modul is installed and permits the MODEM to answer automatically a (N can be set up freely from 1 to 7, or for disabling automatic answer funtion).

FUNCTION 69: DISCONNECTION

Minimum access level: 2

Also this function can be used only when MODEM is installed and it interrupts the current phone connection.

FUNCTION 70: TELEPHONE NUMBER

Minimum access level: 2

When MODEM is installed, it is possible, by this function, to make the phone number to call for data connection or to put MODEM in manual reception.

NOTE. For a correct use of functions 68, 69 and 70 please see TD155 manual, where all the information about serial connections are contained.

FUNCTION 71 DATA PRINTING

Minimum access level: 2

If the extra serial module has been installed, this Function permits the printing of measurement data at either fixed intervals or whenever an alarm is triggered.

FUNCTION 72 RX/TX RE-SENDING

Minimum access level: 2

If the extra serial module has been installed, this Function permits data transit from one serial port to another. This permits the construction of heterogeneous RS485/RS232/MODEM networks for the coverage of different distances and users.

FUNCTION 73 EMPTY TUBE AUTO. REG.

Minimum access level: 2

This Function permits the empty tube detection threshold to be set as required. Regulation is performed by filling and emptying the measurement tube and then memorizing the conductivity value when the tube is empty.

FUNCTION 74 PERSONAL CODE

Minimum access level: 2

This Function is used to modify the programming function ACCESS CODE.

<p style="text-align: center;">IMPORTANT! WRITE DOWN AND JEALOUSLY GUARD THE ACCESS CODE SET</p>

FUNCTION 75 TOTALIZER SHUTDOWN RESET BY EXTERNAL SIGNAL

Minimum access level: 2

This Function is used to enable the shutdown of the totalizers whenever an external RESET signal has been given.

FUNCTION 77 EMPTY TUBE PULSE DURATION

Minimum access level: 2

This Function permits the modification of empty tube test pulse duration.

FUNCTION 78 EMPTY TUBE DETECTION THRESHOLD

Minimum access level: 2

This Function permits the modification of empty tube detection threshold.

FUNCTION 79 SPECIFIC WEIGHT

Minimum access level: 2

This Function permits the entry of the specific weight of the liquid to be measured in kg/dm³ in a range of 0.0001 - 99.9999. This Function is used whenever a unit of weight is used instead of a unit of volume for the measurement of flow rate or totalization.

Note: specific weight is more or less affected by temperature depending on the type of liquid being measured. The measurement error derived must therefore be assessed with the correct attention.

FUNCTION 81 FLOW RATE SIMULATION

Minimum access level: 2

This Function can be used to simulate a flow rate value included in the range of -125.00% and + 125.00 F.S.

FUNCTION 82 INSTRUMENT CONFIGURATION PRINTING

Minimum access level: 2

If the extra serial module has been installed and connection to a printer has been made, this Function permits the printing of all the configuration functions enabled by the respective access level.

APPENDIX 1**TRANSFORMATION FROM COMPACT TO SEPARATE VERSION**

If you own a magnetic flow meter in compact version and you need to separate the converter from the sensor, you can operate as described in the following table.

To carry out this operation you must require to your supplier Company the "separation KIT K108" and furthermore the couple of cables C012 and C013 necessary to connect the sensor to the converter.

Please remember that the optimal length is no longer than 10 m. The KIT K108 includes:

1) wall bracket	to fasten the converter MC 108 to the wall
2) Small cover with screws and grower ring	to close the connection box
3) 5 MA nut with grower washer	
4) 4 mm hexagonal wrench	
5) 5 mm hexagonal wrench	
6) O-ring R25	to insert between support and converter
7) 2 screws 6 MA x 20 (hexagonal wrench)	
8) 1 packet of sealing resin SIP1	necessary to seal the connection box, once connected the cables C012 and C013 (see note pag. 9)
9) 2 metallic cable glands PG11 IP 68	

**APPENDIX 2: - THE MEANING - OPERATION - PROGRAMMING METHODS
FOR A NUMBER OF FUNCTIONS**

A2.1 - FUNCTIONS

05 (response delay),

38 (maximum variance),

39 (response speed threshold)

The *measurement* shown on the display and sent to the delivery is the result of a number of operations performed on the signal sampled. The converter samples the signal at regular time intervals known as scanning cycles. At the end of each cycle a new sample is collected that is then compared with the *measurement*. The difference observed (both in absolute value and expressed in % of the full-scale value) is then compared with the value of Function 38 (maximum variance): se if the result is greater than this latter, the value is limited to that of Function 38.

The same difference is then compared with the threshold for Function 39: if it proves to be greater, the *measurement* immediately assumes the value of the new sample, otherwise the value is gradually modified in a period of time adjusted by Function 05 (response delay). This value is to all effects the measurement system's *time constant*.

The evolution of the *measurement* for a variation in flow rate from 0 to 100% caused only by the effect of the response delay is as follows:

TABLE 2.1

FLOW RATE (%)	MEASUREMENT (%)	TIME
0	0	0
100	69	1T
100	89	2T
100	96	3T
100	99	4T
100	100	5T

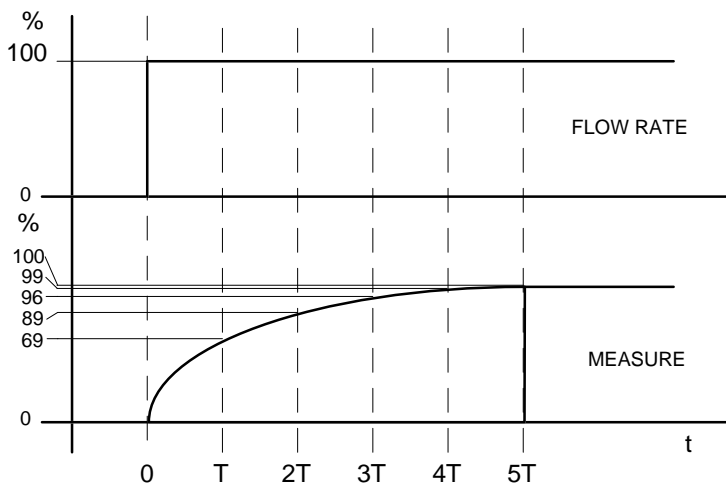

Where T is the value of Function 05.

Let us now suppose that Function 39 is set at 25%; the respective graph will be:

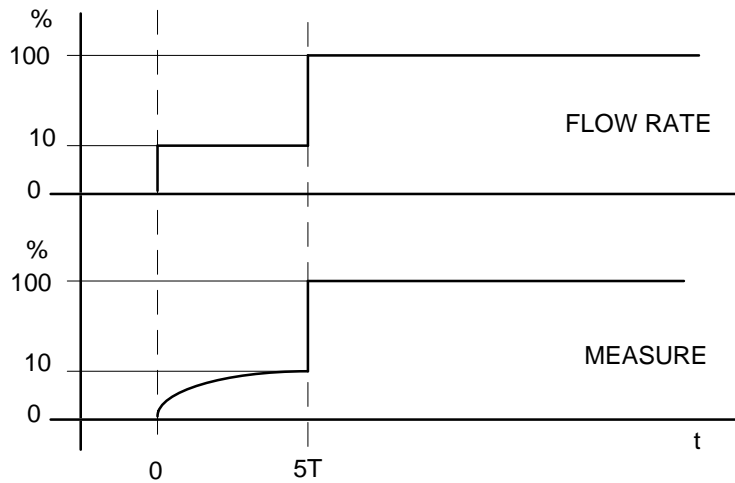

In Point 0 the flow rate varies by 10%. Because the difference is less than 25%, the measurement will be developed by taking account of the response delay and reach 10% after 5 time constants. In the subsequent point, the flow rate varies by 90%: in this case the difference is greater than 25% and therefore the measurement will immediately assume the value of the flow rate.

In summary:

The MAXIMUM VARIANCE (FUNC.38) is useful in order to *limit* momentary peaks in flow rate caused by elements of disturbance: variances greater than the parameter set will be ignored by the flowmeter. Note that the range considered valid for this parameter runs from 0 to 125%, but when the value is set to 0, the flowmeter "freezes" the flow rate value that it measures in that precise instant and does not allow it to vary further. The "standard" value is 100%.

The RESPONSE SPEED THRESHOLD (FUNC.39) is useful to *accelerate* the response supplied by the flowmeter to *greater variances* in flow rate, such as those that occur during the opening or closing of valves, the starting or stopping of pumps, etc. By setting this threshold to zero, an extremely "quick" but equally "turbulent" measurements can be obtained. The "standard" value here is 10%.

The RESPONSE DELAY (FUNC.05) is useful to *lower slight variations* in the flow rate in order to permit stable and precise measurements to be obtained. The value recommended runs from 2 to 10 seconds depending on the diameter.

Significant results in terms of measurement stability and speed and invulnerability to hydraulic turbulence can be achieved by setting these functions appropriately during the installation of the flowmeter.

A2.2 - FUNCTION 10 (FACTORY PRE-SETTING)

The pre-setting data are stored in non-volatile memory, and there are two copies of the data: a *working* copy and a *safety* copy. When the flowmeter leaves the factory, the working and safety data are automatically pre-set at "standard" values and are both identical. When the instrument's configuration parameters are changed, only the working data are modified. Function 10 copies all the safety data (pre-set in factory) over the working data, thereby **CANCELLING ANY MODIFICATIONS MADE**.

NOTE: The "standard" values are those that ensure the instrument's operation in the vast majority of cases. Whenever converters already coupled to the respective sensors are requested (the most frequent case), the "standard" parameters are completed with the sensors' setting coefficients. The resumption of the data through the use of Function 10 is the fastest and most reliable solution whenever the instrument's configuration data have been subjected to tampering.

A2.3 - FUNCTION 14 (OUTPUT SIGNAL TYPE)

The flowmeter can generate pulse-type signals in either of the two different ways selected through the use of Function 14:

1. PULSE: Function 02 (pulse volume) defines the volume of liquid as represented by a pulse (unit volume). Whenever a unit volume passes through the flowmeter, a pulse is generated. At equivalent flow rates, the time interval between one pulse and the next cannot be constant for the following reason:

The converter calculates the volume of liquid that has passed through the sensor at equal and repeated intervals of time, or rather, at every *scanning cycle*. For this reason, the volume calculated case by case regards a given *scanning cycle*. This quantity is compared with the unit volume in order to determine the number of pulses to be emitted. These pulses are emitted during the following cycle. The ON time is equal to the OFF time and this time can be modified by Function 03. The diagram below is the result.

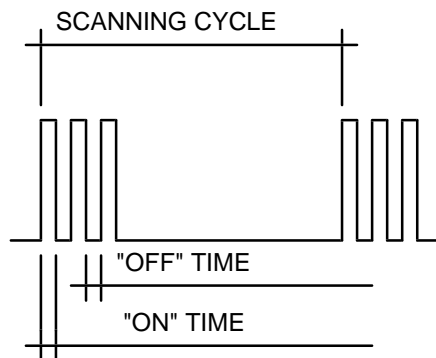

From this we can infer that these pulses are generated in the form of "packets" at each scanning cycle. In other words, these pulses represent a volume that has already *passed* through the flowmeter and are therefore emitted with a delay and for this reason are not distributed along the entire scanning cycle but grouped for the purpose of being acquired in the shortest time possible.

Whenever the pulses are so numerous that they cover the entire scanning cycle, the *maximum* output frequency is reached, or in other words, the maximum number of pulses that can be generated by the instrument *in one second*. If the flow rate were to increase even more after reaching this condition, or if the unit volume were to decrease, the phenomenon of *saturation* would occur, and under such conditions the instrument would be incapable of emitting a sufficient number of impulses and thus begins accumulating those in excess in the memory circuit. When saturation no longer occurs, the pulses that have been accumulated are emitted at the highest frequency possible. This lessens the risk of losing pulses when the flow rate exceeds the working conditions foreseen.

The internal memory has a maximum capacity of approx. 32000 pulses, and for this reason if saturation endures for a long time the risk arises that this number will be exceeded, with the consequent loss of pulses.

In order to avoid saturation during maximum flow rate conditions, the duration and the volume of the pulse must be accurately sized. The most rapid method is the following:

- The minimum duration of the pulse possible compatible with the instrument that must receive it is selected and this value is set with the use of Function 03;
- With the use of Function 01, the full-scale foreseen and expressed in *liters per second (l/s)*, this unit of measure can be applied with all diameters from 3 to 2000 mm;
- Multiply [the value of Function 01] by [the value of Function 03] / 500: this is the smallest volume *in liters* that can be given to the pulse in order to avoid saturation at the maximum presumed flow rate (full-scale);
- With the use of Function 02, set the volume of the pulse *in liters* to a value no lower than the calculated value;
- At this point, the units of measure can be changed (but not the values) for Functions 01 and 02 as desired: the converter will make all the necessary changes automatically.

2. FREQUENCY: The Function 04 permits a frequency value to be associated with the flow rate full scale, so that in this way a frequency proportional to the flow rate measured can be obtained.

The signal generated is symmetrical square wave (duty cycle = 50%) whose frequency is revised after each scanning cycle as may be inferred from the following diagram:

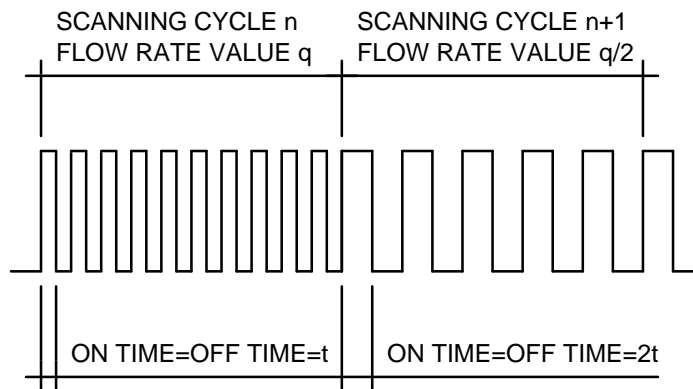

The minimum frequency that can be generated is 0.5 Hz; the maximum is 12500 Hz (MC 108, HS 300) or 1250 Hz (MC 106).

If Function 21 has been enabled (frequency range extension) the frequency can be extended to a maximum of 110% of the full-scale, otherwise it stops at 100%.

The frequency output is used when the flow rate must be transmitted by remote-control, but can also be used for totalization after setting the full-scale value accordingly.

Example: flow rate full-scale = 50 l/s
 frequency full-scale = 50 Hz
 in this case, one pulse is equivalent to one liter.

The use of frequency for totalization is not recommended for mechanical pulse counters that are incapable of withstanding the energization of the coil for an indefinite period: at very low frequencies the output could remain active long enough to burn out the coil.

TABLE 2.2: The two "methods" compared

FREQUENCY	PULSE
pulses distributed over time	"packet"-type pulses
variable pulse duration	constant pulse duration
pulses phased with measurement	pulses delayed after measurement
loss of pulses if $Q > f.s.$	no loss of pulses if $Q > f.s.$
less precision	maximum precision
can be used only with electronic counters	can be used with any type of counters

A2.4. - FUNCTIONS 17 (DUAL RANGE) 18 (AUTORANGING)

Our flowmeters work internally with extremely high resolution and a much higher measurement range than strictly required for the processing of flow rate values. This extra quality serves a dual purpose:

1. The selection of the full-scale value is simplified to a purely mathematical calculation and there are no changes in the flowmeter's characteristics.
2. Regardless of whatever full-scale value has been set, the flowmeter is always capable of making the calculations correctly, and processing the alarms and emitting pulses even with flow rates 50 times greater than the smallest full-scale value.

This must be recognized in order to explain that the full scale value set on the instrument is pertinent to only the following functions:

- the indication of the flow rate in %;
- the 0/4..20 mA output;
- the frequency output;
- the processing of the alarms and thresholds expressed in % of the f.s.

If, for example, a flowmeter is destined for use only as a **mere counter**, the **pre-setting of the full scale is not indispensable**.

In other cases, the selection of the instrument's full scale is essential: the range in which it can distribute the signal processed (in either frequency or current) has a modest degree of resolution, poor dynamics, and elevated error margins. All this only goes to show how important it is to center the instrument's full scale carefully. Lastly, some applications (particularly critical adjustment loops, recording systems, etc.) are greatly facilitated by being able to select one of two measurement scales according to the type of process being monitored.

Function 17 permits the enabling of a double range of measurement (dual range) that is contained "within" the normal range. This system permits the expansion of the field of output in order to provide greater resolution.

When Function 17 is enabled, Function 01 is used to set the two f.s values on the:

- normal range
- low range ("contained" in the above).

Function 18 (autoranging) is used to decide when the low range must be used:

- FLOW RATE VALUE: enabled when the flow rate falls below 90% of the low range.
- FLOW RATE SIGN: enabled when the flow rate is negative.
- EXTERNAL CONTROL: enabled whenever voltage is applied $> 3V$ to the appropriate input (terminals 16 and 17) (only MC 108) or when the appropriate control is received on the serial line.
- MANUAL CONTROL: the [] key is used to select the normal range, the [] key is used to select the low range.

If the user wants the instrument to indicate which range is being used, the following Function must be enabled:

FUNCTION 32, out-of-range alarm

This alarm is generated when the flow rate exceeds the normal range's full scale or whenever the pulse frequency is too high, but if enabled it also signals when the instrument is working with the low range.

This is why it is important to be careful during the pre-setting of the normal range's full-scale (the larger of the two ranges in the system) and the duration/frequency of the pulses: if an out-of-range value is given, the signal could be interpreted as indicating "low range enabled".

The alarm signal or range indication are available (only on the MC 108) on terminals 8 (collector) and 7 (emitter).

A2.5 - FUNCTIONS 20 and 21 (current range/frequency extension)

These Functions can be used to extend the current or frequency range full scale up to 110%. When the current range full scale value is extended (Function 20 enabled) the current can reach a maximum of 22 mA, and then overflow indication will be provided above 110% for the 0..20 mA range and above 112,5% for the 4..20 mA range. If the range full scale is not extended, overflow indication will be provided above 100%.

When the frequency range full scale is extended (FUNCTION 21 enabled) the frequency can reach a maximum of 110% of the full scale value set, above which value overflow indication will be provided. This extension can be performed when the output signal is a frequency that is proportional to the flow rate and not the totalization pulses.

The extension of these ranges is very useful in investigating overflow conditions, otherwise, an indication that the flow rate is really at 100% of the f.s. or even well beyond could be provided.

The effective use of extended ranges depends on the capacity of the receiving instrument to process such information.

A2.6 - FUNCTIONS 45 and 46 (MALFUNCTION CURRENT/FREQUENCY VALUE)

FUNCTION 45 is used to set the current value at which the output signal will be sent when one or any of the following conditions occurs:

- empty tube
- interrupted coils
- ADC error

The range valid runs from 0 to 120% of the 0..20 mA scale, with 120% corresponding to 24 mA. This current value does not depend on the extension of the current range selected with the use of Function 20.

NAMUR NE43 Standards prescribe a malfunction signal current of less than 3.6 mA (<18%) or greater than 21 mA (>105%). It would be better to set Function 45 to 10%, this would bring the current to 2 mA in case of the a.m. malfunctions and permit the diagnostics listed below:

- current < 2 mA - 5%: line interrupted, mains power failure or converter broken;
- 2 mA -5% < current < 2 mA + 5%: hardware alarm condition;
- 4 mA < current < 20 mA: normal measurement range;
- 20 mA < current < 22 mA: overflow, measurement over 100% of f.s.

Obviously the failure signal currents must not be set at values contained within the normal range of measurement.

In the same way, FUNCTION 46 is used to set the value of the output frequency transmitted whenever one or more of the a.m. causes occurs. This Function is enabled only if FUNCTION 14 has been used to enable frequency, rather than pulse output.

The range valid runs from 0 to 125% of the frequency f.s. set, and does not depend on whether the extension of the frequency field has been enabled by the use of FUNCTION 21 or not.

Although no specific regulations exist, the malfunction signal should always be used in the following way:

- 0 Hz < frequency < 100% f.s.: normal measurement range;
- 100% f.s. < frequency < 110% f.s.: overflow, measurements above 100% of the f.s.;
- 115% f.s. < frequency < 125% f.s.: hardware alarm condition.

A2.7 - FUNCTIONS THAT REGARD THE "EMPTY TUBE" CIRCUIT

The MC 108 converter is capable of determining whether the sensor holds liquid or not.

In order to perform this check, a pulse-type signal is generated and applied internally in the electrode circuit. This pulse generates a voltage that is proportional to the resistance "detected" by the electrodes. When the tube empties, the resistance between the electrodes becomes much greater; when the tube fills, this resistance falls considerably. The difference between the two resistance (and consequently voltage) values permits the capable to recognize empty tube conditions.

This method is not infallible for the following reasons, however:

- the test pulse has a very short duration in order to avoid disturbing the measurements and can be significantly weakened by the capacity of the connection cable to the sensor and provide a weak signal as a result;
- the conductivity of the liquids varies widely and when it is low a noisy and unstable signal is provided;
- the sensor may have internal encrustations that withhold a slight layer of liquid that will give erroneous resistance readings.

The conditions required for the best operation of the "empty tube" system are:

1. sensor lined in PTFE
2. converter in compact version
3. high liquid conductivity

The functions that enable "empty tube" circuit operation are as follows:

Table 2.3

function	DESCRIPTION	NOTE
24	empty tube test enabling	enable this function if the empty tube information is to be utilized
73	automatic empty tube recognition parameter adjustment	in order to set the parameters required the tube must first be filled (to moisten the lining and the electrodes) and then emptied tube (per moisten the lining e the electrodes) and then the Function must be enabled. The converter performs a series of tests in order to calculate the optimum parameters. If it is impossible to empty or fill the sensor with liquid, proceed as described below and in any case NEVER ENABLE THIS FUNCTION BEFORE FIRST ENABLING FUNCTION 24.

CASE A, the flowmeter cannot be filled:

1. enable the flowmeter using Function 73
2. use Function 78 as described further on in order to correct the threshold whenever malfunctions occur.

CASE B, the flowmeter is full and cannot be emptied:

- if the flowmeter is compact or in a separate version and the sensor's junction box has been resined, disconnect the wires from the converter's terminals 1 and 2,
- if the flowmeter is separate and the junction box is not resined, disconnect the wires of the CO12 cable from terminals E1 and E2, **making sure that no contact with the wires is made, even with your hands;**
- enable Function 73;
- re-connect the wires to the terminals, and wait a few minutes for the measurement to stabilize: the flowmeter must indicate a full tube; otherwise act on the threshold of Function 78 as described further on.

In these situations in tubes lined with in ebanite, there is unfortunately no guarantee of correct operation when the sensor has finally emptied.

Table 2.4

FUNCTION	DESCRIPTION	NOTE
78	empty tube detection threshold	This parameter is automatically obtained by Function 73 during the setting of the parameters. It can be modified by bearing in mind that a higher number corresponds to lesser sensitivity, or rather, the empty tube condition is detected with lesser ease. On the other hand, low threshold values can give rise to false empty tube indications.
77	empty tube test pulse duration	This parameter is also automatically obtained by Function 73 during parameter setting and even if it CAN be modified it is not very useful to do so. It could be used to see if Function 73 has operated as it should: after setting, on separate flowmeters this datum should be considerably higher than those seen on compact versions. The value is proportional to the duration of the test pulse and is determined in such way as to provide the least amount of disturbance to the measurement that is compatible with the level of the signal to be obtained. The attempt can be made to increase this value whenever the operation of the empty tube is observed to be unstable.

A2.8.- FUNCTION 47 - AUTOMATIC ZERO-SET CALIBRATION

Our converter measurement system ensures high zero stability. In certain cases however it might be necessary to re-calibrate the flowmeter's zero-setting system. This need might be required in the following cases, for example:

- transformation of the flowmeter from compact to separate version and vice-versa;
- periods of long inactivity in which the sensor remains "dry";
- the installation of the sensor in the proximity of strong magnetic fields.

In order to perform this calibration, the operator must be absolutely CERTAIN that the liquid is PERFECTLY stationary, and it is also a good rule to check the sealing of the valves, cocks and all the other hydraulic circuit components for the same purpose, bearing in mind that the instrument is sensitive to liquid speeds of even as low as 0.1 *millimeters/second*.

This calibration is performed by enabling Function 47 by pressing the [] key.

In order to annul the calibration performed, the [] key must be pressed.

By exiting the Function with [E] all the parameters calibrated are saved;
with [C] the entire operation is annulled.

Note that this Function does not automatically return to normal operation after the usual two minutes.

A2.9 - FUNCTION 81 - FLOW RATE SIMULATION

This Function is used when (4..20mA, pulse-type, frequency-type, alarm, etc.) output signals must be obtained and no liquid can be passed into the measurement tube.

A flow rate value from -125 to +125% of the f.s. can be set, zero included.

The effect obtained on the outputs is the same that would be obtained by passing liquid into the flowmeter.

This Function can be very useful during diagnostics in order to check the satisfactory operation of the outputs with reliability.

Note that this Function does not automatically return to normal operation after the usual two minutes.

APPENDIX 3

A3.1 - The following messages are displayed after display:

MESSAGE	CAUSES	SOLUTIONS
"EXCIT.SPEED HIGH"	This message should never be displayed.	Send sensor + converter to the nearest assistance centre for the necessary verifies.
"EXCITAT.FAILURE"	The excitation circuitry (connecting cables) in this circumstance the flow rate measurement is not possible.	Check the integrity of the connecting cables between the sensor and the converter, the tightening of the wires on the terminals, the resistance value of the ohms).
"FLOW MAX.ALARM"	This message does not indicate an error condition but instead it points out a certain process alarm condition. In other words, it means that the readed flow rate is over the programmed max. alarm threshold and the relative on/off output is activated.	Modify the max. alarm threshold using the function 40 (level 2) if it is not correspondent to the desired output or disable the associated on/off output using the function 29 (level 2) if it is not requested by the process.
"FLOW MIN.ALARM"	This message does not indicate an error condition but instead it points out a certain process alarm condition. In other words, it means that the readed flow rate is under the programmed min. alarm threshold and the relative on/off output is activated.	Modify the min. alarm threshold using the function 41 (level 2) if it is not correspondent to the desired output or disable the associated on/off output using the function 30 (level 2) if it is not requested by the process.
"PIPE EMPTY"	The measure pipe (sensor) is empty, the electrodes connecting cable is broken, the sensor or liquid grounding is poor or inefficient, the empty pipe detection circuitry is not correctly calibrated.	Check carefully the sensor if it is COMPLETELY filled of liquid, check the integrity of the electrodes and the ground connecting cables and the tightening of the wires in the terminals. If the connections are OK and the sensor is surely filled, calibrate the empty pipe detection circuitry using the function 73 (level 2), as described in the manual.
"FLOW RATE >F.S."	The measured flow rate value is greater than the full scale set.	Modify the full scale value using the function 01 (level 1).
"IMP./FREQ.>F.S."	The parameters set in the converter cause the generation of a number of totalizing pulses greater than that the instrument can deliver. In this situation the pulses in plus are accumulated in memory and they are delivered as soon as possible.	Increase the volume corresponding to one pulse using the function 02 (level 1) or reduce the pulse time using the function 03 (level 1) accordingly with the external used pulse-counter capability.

MESSAGE	CAUSES	SOLUTIONS
"ADC OVERFLOW"	The sensor is empty, the electrodes connecting cable is broken, the liquid or the sensor grounding is poor or inefficient, the empty pipe detection circuitry is not correctly calibrated, the measure is strongly disturbed by external causes.	Check carefully the sensor if it is COMPLETELY filled of liquid, check the integrity of the electrodes and the ground connecting cables and the tightening of the wires in the terminals. If the connections are OK and the sensor is surely filled, calibrate the empty pipe detection circuitry using the function 73 (level 2), as described in the manual. Finally check in the proximity of the sensor if there are devices that could generate strong electromagnetic fields, like welding machines or similar.

A3.2 - Messages visu

-up:

MESSAGES	CAUSES	SOLUTIONS
"WATCHDOG FAILURE"	The WATCH-DOG circuitry is defective.	Send the converter to the assistance centre for repairing.
"KEYBOARD ERROR"	A key was pressed during the start-up procedure or the keyboard is defective or damaged.	Check if the keys are locked or depressed. If the defect remains, send the converter to the assistance centre.
"DATA NOT VALID"	The configuration data contained in the EEPROM are not valid. This may be caused by a defective EEPROM or by very strong electromagnetic noises.	In the EEPROM exists another copy of the configuration data that is used in this situation. Turn off and on again the converter: if this message still remain, send the converter to the assistance centre.
"INITIALIZE ERROR"	An internal damage has occurred and all the configuration data are lost (also the second copy used for safety).	Send the converter to the assistance centre.
"EEPROM ERROR"	The EEPROM chip is damaged or defective.	Send the converter to the assistance centre.

APPENDIX 4: INCONVENIENCES AND SOLUTIONS

SYMPTOMS	DIAGNOSIS AND SOLUTIONS
The zero reading in absence of flowrate is unstable	Check the grounding of sensor and liquid. Via Function 37 (lev. 2) bring its parameter to, at least, 2%. Via Function 5 (lev. 0) increase its parameter of 0,5 seconds.
The external pulse counter does not count, even in presence of flowrate inside the pipe.	1.- If the display shows the presence of flowrate: a) a volume per pulse too small may have been preset, or there is a flowrate too high and the beat frequency is higher than the pulse counter capability (see APPENDIX 2 paragraph A2.3 and example at paragraph 12.1.C5.1). Increase the unit of volume (Function 2) until you reach a frequency compatible with the pulse counter used. b) a pulse time t1 too high compared to the desired frequency, may have been preset; or it may be too short for the pulse counter chosen. Recalculate according to paragraph 12.1.C5.1 and modify t1 (Function 3). c) the pulse counter has not been correctly connected. Check connections (see fig. 6 and 7). You may ask to the Assistance. d) presetting fault: via Function 14 (lev. 2) check if the output has been preset. 2.- If the display shows null flowrate : a) the empty pipe alarm has occurred. Disable the alarm via Function 24 and in case the display starts to indicate the flowrate, please adjust parameters by Functions 73 and 78 before enabling again this alarm (see Appendix 2, paragraph A2.7). b) there is a high zero offset . C calibration according to Appendix 2, paragraph A2.8.
The flowrate reading is very unstable.	1 - There is no grounding of sensor and liquid. Perform it according to 7.4. 2 - The liquid conductivity is too low. Ask to the Assistance . 3 - The totalizing threshold (Function 37) is too low. Increase it . 4 - There is air in the pipe or steam for pressure next to zero. Choose a more suitable position for the sensor (see paragraph 7.1). Sometimes the problem may be momentary solved by closing partly the valve downstream of the meter. 5 - Presetting faults: via Function 5 (lev. 0) increase its parameter of 0,5 seconds; via Function 38 (lev. 2) decrease its parameter of 50%; via Function 39 (lev. 2) increase its parameter of 50%.
The display is off.	1.- There is no power supply voltage. Check the value on the converter data plate and activate the power supply (12.1.E). 2.- The fuse is broken. Switch off the converter, replace the fuse (see 12.1.F), close the cover, switch on the converter.
With empty pipe, the display shows flowrate / the totalizer moves .	Enable
With motionless liquid, the display shows flowrate / the totalizer moves .	calibration via Function 47 (lev. 2) (see Appendix 2, paragraph A2.8).

THE DOCUMENTS CONCERNING THE TO SERIAL COMMUNICATIONS PERFORMABLE BY MC 108 IS COLLECTED IN TD 155/ENG MANUAL, WHICH CAN BE REQUIRED TO THE SUPPLIER COMPANY.